



## NEHRP Seismic Design Technical Brief No. 12



# Seismic Design of Cold-Formed Steel Lateral Load-Resisting Systems

A Guide for Practicing Engineers

---

**Robert L. Madsen**  
**Thomas A. Castle**  
**Benjamin W. Schafer**

This publication is available free of charge from:  
<http://dx.doi.org/10.6028/NIST.GCR.16-917-38>

## NEHRP Seismic Design Technical Briefs

National Earthquake Hazards Reduction Program (NEHRP) Technical Briefs are published by the National Institute of Standards and Technology (NIST) as aids to the efficient transfer of NEHRP and other research into practice, thereby helping to reduce the nation's losses resulting from earthquakes.

## NIST National Institute of Standards and Technology

NIST is a federal technology agency within the U.S. Department of Commerce that promotes U.S. innovation and industrial competitiveness by advancing measurement science, standards, and technology in ways that enhance economic security and improve our quality of life. NIST is the lead NEHRP agency. Dr. Steven L. McCabe is the Earthquake Engineering Group (EEG) Leader within the Materials and Structural Systems Division of the Engineering Laboratory at NIST. The EEG supports the work of the NEHRP program at NIST.

## Applied Technology Council

The Applied Technology Council (ATC) is a nonprofit corporation advancing engineering applications for hazard mitigation. This publication is a product of Task Order 15-347 under Contract SB1341-13-CQ-0009 between ATC and NIST. Jon A. Heintz serves as the Program Manager for work conducted under this contract, and Scott Schiff serves as ATC Associate Program Manager on this Task Order.

## Consortium of Universities for Research in Earthquake Engineering

The Consortium of Universities for Research in Earthquake Engineering (CUREE) is a nonprofit organization advancing civil engineering research and education to increase the resilience of the built environment to natural and manmade hazards. This publication was produced under a cooperative agreement between ATC and CUREE. Robert Reitherman served as Associate Program Manager overseeing production. Reed Helgens and Darryl Wong served as report production and report preparation consultants for this work.

## About the Authors

**Robert L. Madsen, P.E.**, is a senior engineer with Devco Engineering, Inc. in Enterprise, Oregon where he specializes in the design of cold-formed steel framing. He serves on the American Iron and Steel Institute's (AISI) Committee on Specifications and Committee on Framing Standards; he currently chairs the Lateral Subcommittee. In 2016, he served as the chair of the Technical Review Committee of the Cold-Formed Steel Engineers Institute (CFSEI) and received that organization's Distinguished Service Award in 2014.

**Thomas A. Castle, S.E.**, is a Principal with Ficcadenti Waggoner and Castle Structural Engineers and manages the office in Walnut Creek, California. His interest and experience is in design of earthquake resistant structures, seismic analysis of existing structures, and risk assessment of existing structures. He is the Engineer of Record on over

1,000,000 square feet of load-bearing cold-formed steel projects. He has conducted seminars and webinars on cold-formed steel design for the Structural Engineers Association of Northern California (SEAONC) and the CFSEI and provides structural consulting for cold-formed steel product development. He is a registered professional engineer in 25 states.

**Benjamin W. Schafer, Ph.D.**, is the Swirnow Family Faculty Scholar in the Department of Civil Engineering at Johns Hopkins University. He is active in engineering consulting through his work with NBM Technologies. Prior to joining Johns Hopkins he worked as a Senior Engineer at Simpson Gumpertz & Heger Inc. in Boston, Massachusetts. He is the chair of the Structural Stability Research Council and past-President of CFSEI. He serves on both the AISI and American Institute of Steel Construction (AISC) specification committees that create the nation's standards for cold-formed and hot-rolled steel structures.

## About the Reviewers

The contributions of the reviewers for this publication are gratefully acknowledged.

**Jeff Ellis, P.E., S.E.**, is the Director of Codes & Compliance for Simpson Strong-Tie Company Inc. He has more than 25 years of construction industry experience and manages the company codes and compliance efforts. Additionally, he is involved in research and development and provides technical support for connectors, fastening systems, and lateral force resisting systems. He was a practicing design engineer for commercial, residential and forensic projects for more than 9 years prior to joining Simpson Strong-Tie in 2000. He currently serves as the President for the Structural Engineers Association of Southern California (SEAOSC), a SEAOC Director, a CALBO Structural Safety Committee member, and as a Manager on the ICC-ES Board of Managers. He served as AISI COFS Lateral Design Subcommittee Chairman for several years and as the Cold-Formed Steel Engineers Institute (CFSEI) President.

**Meaghan C. Halligan, P.E., S.E.**, LEED AP BD+C, is the Principal Structural Engineer at ISAT Seismic Bracing in Fremont, California. She previously managed the ISAT cold-formed steel engineering division. Prior to ISAT, she worked at several Bay Area engineering consulting firms and developed experience in the design of multifamily residential structures, seismic upgrades of commercial buildings, and light-gage steel tenant improvements. She is a member of the SEAONC Seismology Nonstructural Subcommittee and is a past chair of the SEAONC Disaster and Emergency Services Committee.

**Chia-Ming Uang, Ph.D.**, is a Professor in the Department of Structural Engineering at the University of California, San Diego. He serves on the AISC Committee of Specifications, Committee of Research, and Connection Prequalification Review Panel. Professor Uang conducts research on the seismic design, rehabilitation, and testing of large-scale steel structures. He received the T.R. Higgins Lectureship Award in 2015 and a Special Achievement Award in 2007 from AISC. He also received three research awards from the American Society of Civil Engineers and the Moisseiff Awards in 2004 and 2014.



**Applied Technology Council (ATC)**  
201 Redwood Shores Parkway, Suite 240  
Redwood City, CA 94065  
(650) 595-1542 | email: [atc@atccouncil.org](mailto:atc@atccouncil.org)  
[www.atccouncil.org](http://www.atccouncil.org)



**Consortium of Universities for Research in Earthquake Engineering (CUREE)**  
1301 South 46th Street, Building 420  
Richmond, CA 94804  
(510) 665-3529 | email: [curee@curee.org](mailto:curee@curee.org)  
[www.curee.org](http://www.curee.org)

NIST GCR 16-917-38

# Seismic Design of Cold-Formed Steel Lateral Load-Resisting Systems

## A Guide for Practicing Engineers

Prepared for  
*U.S. Department of Commerce  
National Institute of Standards and Technology  
Engineering Laboratory  
Gaithersburg, MD 20899-8600*

By  
*Applied Technology Council*

In association with the  
*Consortium of Universities for Research in Earthquake Engineering*

and  
Robert L. Madsen  
Thomas A. Castle  
Benjamin W. Schafer

This publication is available free of charge from:  
<http://dx.doi.org/10.6028/NIST.GCR.16-917-38>

August 2016



U.S. Department of Commerce  
*Penny Pritzker, Secretary*

National Institute of Standards and Technology  
*Willie May, Under Secretary of Commerce for Standards and Technology and Director*

## Contents

1. Introduction .....	1
2. Brief History of the Use of CFS Load-Bearing Framing and Lateral Systems.....	4
3. Construction Methods.....	8
4. Seismic Force-Resisting Systems.....	12
5. Diaphragms.....	20
6. Cyclic Performance of CFS Seismic Force-Resisting Systems.....	22
7. Advanced CFS SFRS Topics.....	30
8. ASCE 41 Applications.....	36
9. Additional Considerations.....	37
10. Special Bolted Moment Frames (CFS-SBMF).....	40
11. The Future of CFS Seismic Force-Resisting Systems and Design.....	41
12. References.....	44
13. Notations and Abbreviations.....	50
14. Credits.....	52

## Disclaimers

This Technical Brief was prepared for the Engineering Laboratory of the National Institute of Standards and Technology (NIST) under the National Earthquake Hazards Reduction Program (NEHRP) Earthquake Structural and Engineering Research Contract SB1341-13-CQ-0009, Task Order 15-347. The contents of this publication do not necessarily reflect the views and policies of NIST or the U.S. Government.

This report was produced by the Applied Technology Council (ATC) in association with the Consortium of Universities for Research in Earthquake Engineering (CUREE). While endeavoring to provide practical and accurate information, ATC, CUREE, the authors, and the reviewers assume no liability for, nor express or imply any warranty with regard to, the information contained herein. Users of information in this report assume all liability arising from such use.

Unless otherwise noted, photos, figures, and data presented in this report have been developed or provided by ATC staff, CUREE staff, or consultants engaged under contract to provide information as works for hire. Any similarity with other published information is coincidental. Photos and figures cited from outside sources have been reproduced in this report with permission. Any other use requires additional permission from the copyright owners.

Certain commercial software, equipment, instruments, or materials may have been used in preparing information contributing to this report. Identification in this report is not intended to imply recommendation or endorsement by NIST, nor is it intended to imply that such software, equipment, instruments, or materials are necessarily the best available for the purpose.

**Cover photo**—Three-story hotel under construction with load-bearing cold-formed steel framing and a combination of wood-sheathed and steel-sheathed shear walls.

---

## How to Cite This Publication

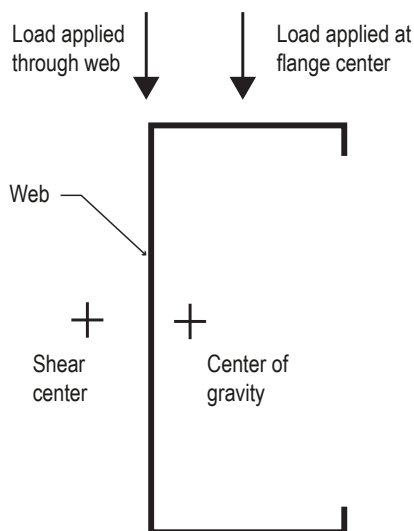
NIST (2016). *Seismic design of cold-formed steel lateral load resisting systems: A guide for practicing engineers*, GCR 16-917-38, NEHRP Seismic Design Technical Brief No. 12, produced by the Applied Technology Council and the Consortium of Universities for Research in Earthquake Engineering for the National Institute of Standards and Technology, Gaithersburg, MD.

# 1. Introduction

Cold-formed steel (CFS) framing has been successfully used in a variety of construction applications for many years. Common uses include nonstructural partitions and ceilings, exterior curtain wall and façade support, and complete load-bearing structures, including lateral force-resisting systems (LFRS). Recent advances in the understanding of CFS framing and ongoing research related to the design of seismic force-resisting systems (SFRS) are expected to expand the use of cold-formed steel framing into more complex, robust structural systems. This Guide focuses specifically on the use of cold-formed steel SFRS in buildings.

Standard analysis and design procedures apply to cold-formed steel design. However, because CFS shapes often include elements with high width-to-thickness ratios, limit states not common to other construction materials must be considered in the design process. These limit states are discussed in Section 2.1.

Additional complexity arises because many CFS members are open, singly symmetric sections. For these sections, the shear center does not coincide with the center of gravity or with common points of load application, which are typically the flange center or the web of the member (see **Figure 1-1**). This misalignment creates warping torsional stresses that, if unbraced, must be addressed per AISI S100-12 §C3.6, *North American Specification for the Design of Cold-Formed Steel Structural Members* (AISI 2012).



**Figure 1-1.** Shear center of typical C-stud.

## Nonstructural CFS Framing

In addition to use as structural members as part of the LFRS of structures, CFS framing is commonly found in nonstructural uses, such as partitions and ceilings. The nonstructural members and their connections must be designed for seismic forces and other forces at the element and component levels as specified in ASCE/SEI 7-10 *Minimum Design Loads for Buildings and Other Structures* (ASCE 2010), referred to in this Guide as ASCE 7. Seismic design of elements and components must consider the component self-weight as well as any permanently attached items, such as casework or wall-mounted equipment. Examples of non-seismic forces that must be considered include a minimum partition lateral live load of 5 psf (240 Pa), live loads for grab bars and handrails, ceiling live loads, and pressures created by moving elevator cars in elevator shafts.

A number of construction types take advantage of cold-formed steel for all or part of the LFRS of a building. Examples include the following:

- Light-frame bearing wall structures with gravity systems constructed of CFS joists or trusses supported by CFS load-bearing walls and a LFRS using CFS shear walls or strap-braced walls
- Podium-type structures where a complete CFS light-frame, load-bearing structure is built atop lower levels of different construction, such as concrete or structural steel
- Mixed systems where CFS joists, trusses, and load-bearing walls are used for the primary gravity system, diaphragms, and collectors but where concrete shear walls or structural steel braced or moment-resisting frames are used for the vertical elements of the LFRS
- Penthouse structures at the uppermost levels of concrete or structural steel buildings; the penthouse LFRS is typically designed per ASCE 7 Chapter 13 as an architectural component rather than as part of the building's LFRS



CFS SFRSs typically fall into one of the following categories:

- Shear walls with wood structural panels (plywood or oriented strand board (OSB)) attached to cold-formed steel studs and tracks
- Shear walls with steel sheet sheathing attached to cold-formed steel studs and tracks
- Cold-formed steel light-frame strap-braced wall systems (diagonal, tension braced walls)
- Special Bolted Moment Frames (SBMF)
- Proprietary products not specifically recognized by AISI S400-15, *North American Standard for Seismic Design of Cold-Formed Steel Structural Systems* (AISI 2015b), including shear walls with steel sheet adhered to other sheathing materials, such as gypsum board; proprietary and alternate SFRSs are discussed in Section 4.4

Cold-formed steel structural members are designed per AISI S100-12, and AISI S240-15, *North American Standard for Cold-Formed Steel Structural Framing* (AISI 2015a). Seismic design of cold-formed steel framing systems is currently per AISI S213-07/S1-09, *North American Standard for Cold-Formed Steel Framing—Lateral Design with Supplement No. 1* (AISI 2009). However, AISI S213 is being replaced by AISI S400-15. In Seismic Design Category A, Seismic Design Category B and Seismic Design Category C, as defined in ASCE 7 when the Response Modification factor,  $R$ , is taken as 3, AISI S100-12 or AISI S240-15 can be used.

ASCE/SEI 41-13, *Seismic Evaluation and Retrofit of Existing Buildings* (ASCE 2014), provides minimal guidance on cold-formed steel framing. However, efforts are underway to include comprehensive cold-formed steel provisions in the next version of ASCE, expected to be published in 2017.

This Guide is written primarily with practicing structural engineers in mind but covers topics that may be of interest to building officials, students, and researchers. It has been developed with the understanding that cold-formed steel design is a specialty that many structural engineers have limited exposure to in either education or practice. Thus, it attempts to cover both introductory and advanced topics.

Section 2 of this Guide briefly discusses the history of CFS load-bearing and lateral force-resisting systems, and Section 3 covers construction methods. Section 4 discusses CFS seismic force-resisting systems, and Section 5 discusses the design of one key element of such systems, diaphragms. Cyclic performance based on results of laboratory testing is provided in Section 6. Advanced topics are discussed in Section 7, the application of ASCE 41 in Section 8, quality assurance in Section 9, and SBMFs in Section 10. Because CFS seismic force-resisting systems have evolved relatively recently compared to most other systems, Section 11 discusses in-progress and future possible developments. The Guide concludes with references, notations, abbreviations, and credits.

## CFS Terminology

Certain terms common to cold-formed steel design may not be familiar to engineers who do not design CFS systems on a regular basis. Below are several terms and definitions. Definitions taken from AISI S400-15 are noted.

**Lateral Force-Resisting System (LFRS):** The structural elements and connections required to resist racking and overturning because of wind forces, or seismic forces, or other predominantly horizontal forces, or combinations thereof, imposed upon the structure in accordance with the applicable code (AISI S400-15). The LFRS is a broader term than SFRS; the LFRS transfers and resists lateral forces and includes the SFRS as well as the other elements and connections in the lateral load path.

**Seismic Force-Resisting System (SFRS):** That part of the structural system that has been selected in the design to provide energy dissipation and the required resistance to the seismic forces prescribed in the applicable standard (AISI S400-15). Examples of CFS SFRS are shear walls with wood structural panels (WSP), shear walls with steel sheet sheathing, strap-braced walls, and SBMF.

**Available Strength:** Design strength or allowable strength as appropriate (AISI S400-15). For Allowable Strength Design (ASD), available strength is nominal strength divided by the specified safety factor,  $\Omega$ . For load and resistance factor design (LRFD), available strength is nominal strength multiplied by the specified resistance factor,  $\phi$ .

**Chord Stud:** Axial load-bearing studs at the ends of Type I shear walls or Type II shear wall segments, or strap-braced walls (AISI S400-15). Chord studs support the overturning tension and compression forces of shear walls or strap-braced walls and are anchored to lower stories via inter-story ties or to the foundation with hold-downs and anchors.

**Designated Energy Dissipating Mechanism:** Selected portion of the SFRS designed and detailed to dissipate energy (AISI S400-15). This is the critical, protected mechanism of the SFRS to which other elements in the seismic load path must be capable of delivering load.

**Expected Strength Factor:** The expected strength factor,  $\Omega_E$ , is the multiplier applied to nominal shear wall strength in accordance with AISI S400-15 as a means to estimate upper bound strength used for capacity-based design of critical elements of the seismic load path. AISI S400-15 provides guidance relative to which elements of the LFRS require application of the expected strength factor.

**Structural 1 Plywood:** Structural 1 is a designation applied to the APA Rated Sheathing where enhanced racking and cross-panel strength properties are of maximum importance. Structural 1 panels are typically used in demanding applications, such as structural shear walls and panelized roofs as defined in the American Plywood Association (APA) Product Guide, *Performance-Rated Panels Guide* (APA 2011).

## 2. Brief History of the Use of CFS Load-Bearing Framing and Lateral Systems

### 2.1 History of the Use of CFS Load-Bearing Framing

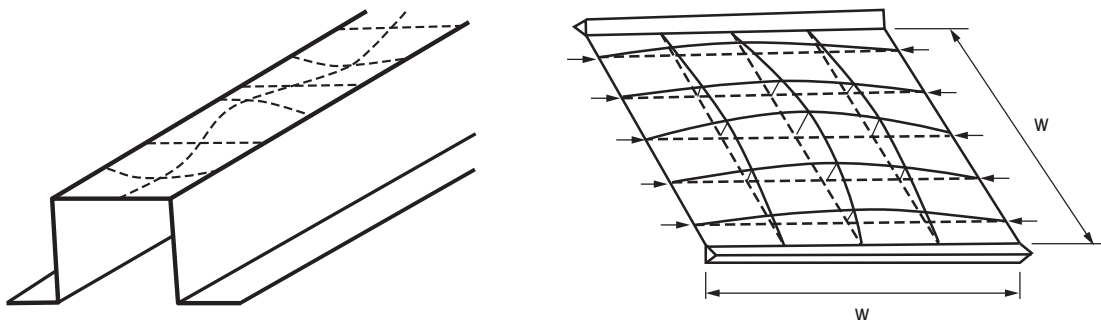
The idea that sheet steel could be used to create mass-market CFS framing applicable to low-rise construction and housing has existed for some time. Allen (2006) summarizes the adoption and application of CFS framing in the late 19<sup>th</sup> century and first half of the 20<sup>th</sup> century. The modern era was kick-started by the abundance of sheet steel production capability and the desired conversion of that capacity from military to domestic ends following World War II. Steel mills in the United States, through the American Iron and Steel Institute (AISI), invested in research conducted at Cornell University by George Winter (see complete history in Winter 1972) to formally create a specification for cold-formed steel structural members. This effort culminated in the 1946 *AISI Specification for the Design of Light Gage Steel Structural Members* (AISI 1946), which was subsequently adopted by building codes. Through its various iterations, it has become the governing standard for CFS structural members today, AISI S100-12.

A number of challenges faced Winter when he began the task of developing design specifications for CFS structural members, chief among them the desire to use sheet steel and keep the material as thin as possible. This desire reflected production and manufacturing conveniences and the over-arching objectives of economy and efficiency. However, the choice was a departure for civil engineering construction because the behavior of the thin sheets that were used to form the members was different from classic hot-rolled steel shapes. Although

the thin sheets would deform and locally buckle under load, they were also able to take substantial post-buckling load due to transverse membrane stresses that developed as the plates deformed (see **Figure 2-1**).

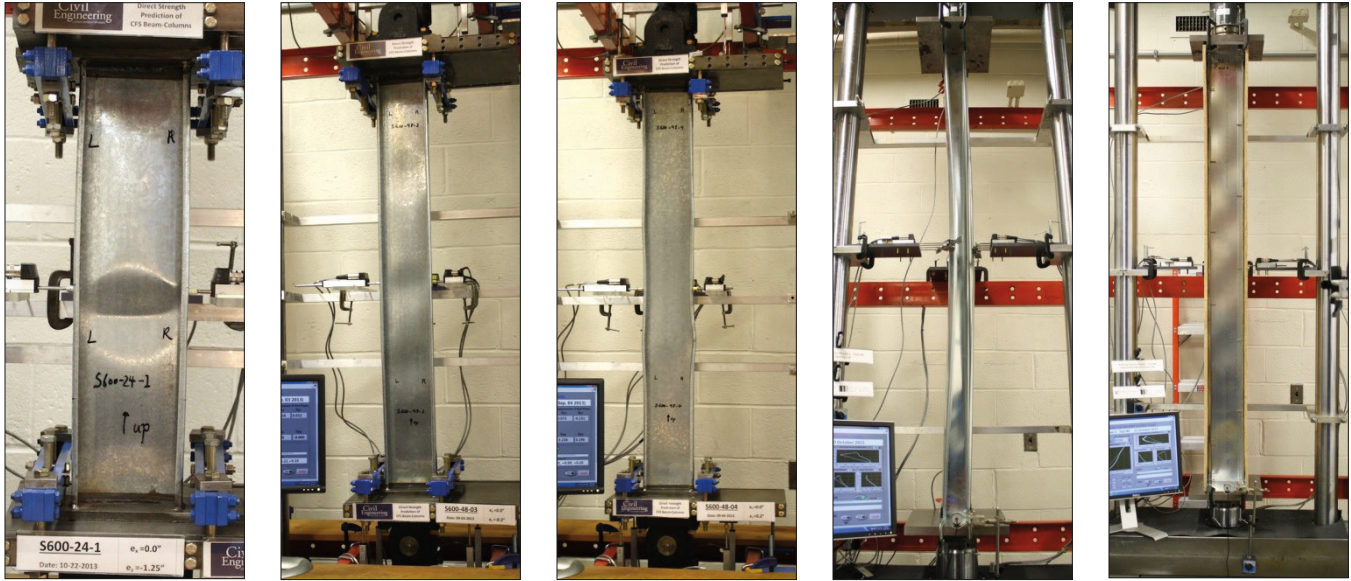
This local buckling phenomenon and post-buckling capacity required new thinking, along with a new design approach and experiments to validate them. Winter developed a semi-empirical method that provided a means for predicting the strength of individual CFS members: the effective width method (Winter 1947). This method exists to this day in AISI S100-12 even as it has been complemented by methods leveraging modern computational power (Schafer 2008 and AISI 2012). The result is that the design of CFS structural members differs from the design of hot-rolled steel members in some important ways.

To understand these differences, consider the two most typical members employed in CFS framing: the lipped and plain channel, more commonly known as the stud and track. Stud and track are typically thin, 0.033 to 0.097 inch (0.84 to 2.46 mm), so localized load must be treated with care. CFS member design must consider at least three distinct buckling phenomena: local buckling, distortional buckling, and global buckling, as illustrated for common studs loaded in compression in **Figure 2-2**. Local buckling has significant post-buckling reserve, distortional buckling has modest post-buckling reserve, and global buckling has minimal post-buckling reserve. These buckling modes and the thin-walled nature of these cross-sections are discussed in AISI S100-12 and in textbooks such as Yu and LaBoube (2010).



**Figure 2-1.** Winter's depiction of local buckling in the compression flange of a hat-shaped cold-formed steel beam and his grid model for explaining how transverse membrane stresses create the source of post-buckling strength in plates under load.





(a) Local buckling leading to plastic mechanism in the web, after peak capacity is reached, in unbraced 2 feet (0.6 m) stud

(b) Local buckling in the web, prior to reaching peak capacity, in unbraced 4 feet (1.2 m) stud

(c) Distortional buckling (note movements of lip and flange), prior to reaching peak capacity, in unbraced 4 feet (1.2 m) stud

(d) Global (flexural-torsional) buckling of a single unbraced 6 feet (1.8 m) stud, past peak capacity

(e) Local buckling in a 6 feet (1.8 m) stud with sheathing attached to the flanges, thus restricting global buckling

**Figure 2-2.** Observed deformations in typical cold-formed steel studs tested in compression.

### AISI Publications

The AISI maintains a website with links to all applications of cold-formed steel standards, including links to relevant trade associations, at [www.buildusingsteel.org](http://www.buildusingsteel.org). This site provides a useful starting point for applications outside of the scope of this Guide.

AISI S100-12 provides structural criteria for individual CFS members and steel-to-steel connections appropriate for sheet steel. It is possible to design structural CFS framing using only the provisions of AISI S100-12. However, recognizing that CFS framing is a system and not just an assemblage of individual members, AISI created a new Committee on Framing Standards in 1997. The Committee’s work has led to significant evolution of the available standards for CFS framing, as summarized in **Table 2-1**.

Year	Nonstructural Systems		Structural Systems						Seismic Force Resisting Systems	
	S220	S200	S240		S212	n/a	S214	S213	S110	
2016										S210
2012										
2007										
2004	n/a	GP	n/a	WSD	Header		Truss	Lateral	n/a	
2001				n/a				n/a		
	Drywall Framing (Walls and Ceilings)	General Provisions	Floor and Roof Systems	Wall Studs	Headers	Quality Control and Quality Assurance	Trusses	Shear Walls, Strap Braced Walls, and Diaphragms	Special Bolted Moment Frames	
							Ordinary Systems	Special Seismic Systems		

**Table 2-1.** Evolution of AISI standards in cold-formed steel framing (Schafer et al. 2015).

## AISI CFS Framing Standards

AISI Cold-Formed Steel Framing Standards are available at no charge through the Cold-Formed Steel Engineers Institute website: [www.cfsei.org/publications](http://www.cfsei.org/publications).

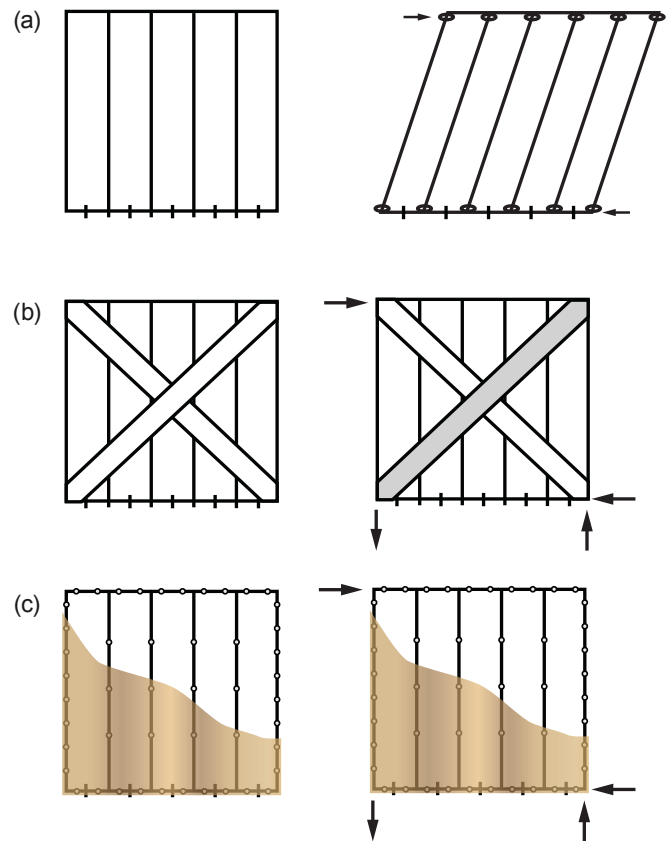
Today, structural CFS framing is addressed in AISI S240-15, nonstructural applications in AISI S220-15, *North American Standard for Cold-Formed Steel Framing-Nonstructural Members* (AISI 2015c), CFS SFRSs in AISI S400-15. These standards provide the engineer direct guidance on how to use AISI S100-12 for CFS framing design and supplement AISI S100-12 where appropriate. Thus, all of these standards remain reliant on AISI S100-12, even as they augment the standard with additional guidance and provisions. For example CFS-framed, wood structural panel shear walls are designed per AISI S400-15, including prediction of the overall demands on chord studs. However, the capacity of the chord studs is still determined using AISI S100-12.

## 2.2 History of CFS Lateral Force-Resisting Systems

Lateral systems in buildings have taken longer to evolve than gravity systems. Early gravity systems in masonry were able to provide adequate lateral support in part through their own massive self-weight. At the turn of the 20<sup>th</sup> century, the advent of lighter and taller steel framed buildings introduced a variety of braced and moment frame systems for hot-rolled steel structures. Cold-formed steel analogs of traditional braced and moment frame systems have proven challenging. The thinness of a cold-formed steel member makes it difficult to provide significant rigidity at the connection points and invariably leads to partially restrained connections at best, leaving most cold-formed steel moment frame systems relatively inefficient. Close spacing of members has been found to be the most efficient arrangement for gravity loading in cold-formed steel framing, but this makes concentric bracing through the webs complex because in that case multiple members need to penetrate across a single diagonal brace. The result is that lateral systems for cold-formed steel framing follow more of the traditions found in timber construction than in hot-rolled steel construction, which can be a challenge for the engineer well-versed in hot-rolled steel systems.

As illustrated in **Figure 2-3**, a bare cold-formed steel framing panel, consisting of studs and track, has little

to no lateral resistance. Typically only a single fastener connects the stud to the track, and the small resistance that develops through bearing at the stud ends and bending of the studs themselves about their minor axis is insufficient to resist lateral load. Two common cold-formed steel lateral systems are strap-braced walls and sheathed panels. Strap-braced walls employ diagonal flat strap connected on one or both of the faces of the wall panel and resist lateral load primarily through truss (axial) action as illustrated in **Figure 2-3**. Sheathed panel systems include cold-formed steel frames sheathed with wood structural panels, gypsum board, fiberboard, and steel sheet. Under lateral load, the framing deforms in shear while the sheathing rotates, which creates differential demands at all the fastener locations, thus developing the primary mechanism resisting lateral loads.



**Figure 2-3.** Cold-formed steel framed panels: (a) bare panel with little to no lateral resistance, (b) strap-braced panel with lateral resistance developed through tension strap and (c) sheathed panel with lateral resistance developed at fastener locations throughout panel. Only applied lateral load, vertical forces in chord studs, and force transfer to the level below are depicted.

Significant research and specification committee activity at AISI has been conducted in the last 20 years to characterize and codify the performance of SFRSs using CFS framing. In the United States, the work of Serrette

et al. (1997b) provided characterization of cold-formed steel-framed, wood-sheathed, shear wall panels that were adopted in the 1997 *Uniform Building Code* (ICBO 1997) and codified into AISI standards: AISI (AISI 2004), AISI S213-07 (AISI 2007), AISI S213-07/S1-09, and AISI S400-15. These publications formed the initial basis for LFRSs framed from cold-formed steel members. Rogers and colleagues added to the effort significantly and expanded the scope for cold-formed steel-framed, wood-sheathed, shear wall panels (Branston et al. 2006), developed experimental performance data, and an understanding of the details of cold-formed steel framed steel strap (Al-Kharat and Rogers 2007), steel sheet shear walls (Balh et al. 2014), and multi-story shear walls (Shamim et al. 2013). Rogers' work was also codified in AISI S213-07 and S213-07/S1-09, along with additional testing by Yu on steel sheet shear walls Yu (2010). Testing protocols and evaluation of the test data have evolved through the years and is discussed in the commentary to AISI S213 and AISI S400. The hysteretic performance of these systems is discussed further in Section 6 of this Guide.

formed steel framing in low-rise (primarily residential) construction in that country also led to useful experimental and full-scale response results on cold-formed steel framed structures (Gad et al. 1999). Recent economic growth in China has created additional research in this area as well, particularly experimental efforts (Li et al. 2012).

Section 11 of this Guide discusses the effect that future research may have on CFS design.

#### **Lateral Systems and Diaphragms Using CFS Members and Metal Deck**

A significant amount of research on lateral systems and diaphragm systems using cold-formed steel members and metal deck has also been conducted. This body of work is not used directly in cold-formed steel framing, but is used in metal building systems. Readers interested in this work may find codified provisions in AISI S310-13, *North American Standard for the Design of Profiled Steel Diaphragm Panels* (AISI 2013a) and Chapter I of the next version of AISI S100 (AISI 2016a) and general discussion in Yu and LaBoube (2010).

A great deal of work has been conducted abroad as well. In Europe, multi-year efforts in Italy and Romania stand out as contributing to the state of the art. In Italy, Landolfo and colleagues performed CFS-framed wood-sheathed shear wall tests (Landolfo et al. 2006), fastener testing (Fiorino et al. 2007), prototype structures (Iuorio et al. 2014), and complete design philosophies (Fiorino et al. 2009). In Romania, Fülöp and Dubina performed CFS-framed wood- and plaster-sheathed shear wall tests (Fülöp and Dubina 2006), complementary numerical models (Fülöp and Dubina 2004) and also developed full seismic design procedures (Dubina 2008). Although Australia is not seismically highly active, the early adoption of cold-

## 3. Construction Methods

### 3.1 Panelization of Framing

The CFS structural system is composed of repetitive framing of a large number of individual pieces. The studs and joists are typically spaced up to 24 inches (610 mm) on center, and bearing walls are typically placed at 12 feet to 20 feet (3.7 m to 6.1 m) on center. The typical project will have hundreds or thousands of pieces to be configured in the final structure. The pieces (e.g., studs, joists, tracks, clips, etc.) are lightweight and easy to handle. These two characteristics are advantages of this type of system over others. However, the number of pieces does require significant assembly time to complete the structure.

The overall goal of most designs is to minimize the amount of labor and material resources to reduce construction costs and time. CFS systems are very efficient at minimizing material. One way to minimize labor and the duration of the construction process is to fabricate the individual pieces into larger subassemblies prior to shipment to the construction site. This process is commonly known as panelization because of the subassemblies resembling a panel. The panels are commonly wall elements containing tracks and studs or can be floor elements containing joists and tracks. The panels may have wall, roof, or floor sheathing installed before shipment to the construction site.

Advantages to panelization include the following:

- Some of the assembly is done in a controlled interior environment. This allows some construction to occur indoors and not be exposed to adverse weather conditions.
- Repetitive sub-assemblies can be constructed using set-up jigs, allowing for efficient assembly.
- Quality control of the assembly may be superior over in-field assembly.
- Erection time may be significantly reduced over conventional field assembly, particularly if designs are completed prior to commencement of construction on site.

There are also some disadvantages to panelization, including the following:

- Construction tolerances and fit-up of panels to foundations and other parts of structure that may have larger dimensional tolerances can be problematic and require special consideration.
- Fast-track projects may not allow for design and preconstruction time required for panelization.
- Late modifications to designs may be difficult if panels have been fabricated early.
- Transportation and crane costs may be higher than for field-built structures due to the weight and size of subassemblies, although CFS panels are still generally lighter than other construction materials. Nesting panels together to reduce truck trips may minimize this issue (see **Figure 3-1**).



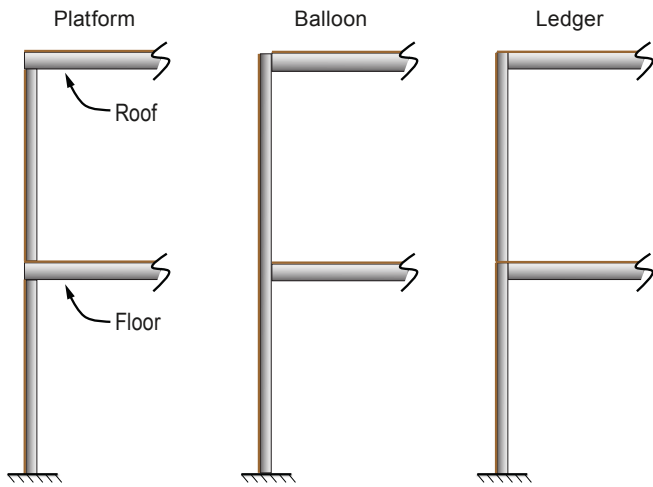
**Figure 3-1.** Example of panelized floor being erected.

LFRSs for both panelized and field-built systems are virtually identical. In panelized systems specific details are required to transfer forces across subassemblies. Wall panels adjacent to one another forming a longer shear wall and drag elements that cross floor or wall subassemblies require specific detailing. Details should consider the fit-up tolerances associated with the subassemblies.

### 3.2 Platform and Ledger Framing Options

The two basic framing alternatives in CFS construction are platform framing and ledger framing. A third, less frequently used, balloon framing system is also shown in **Figure 3-2**.



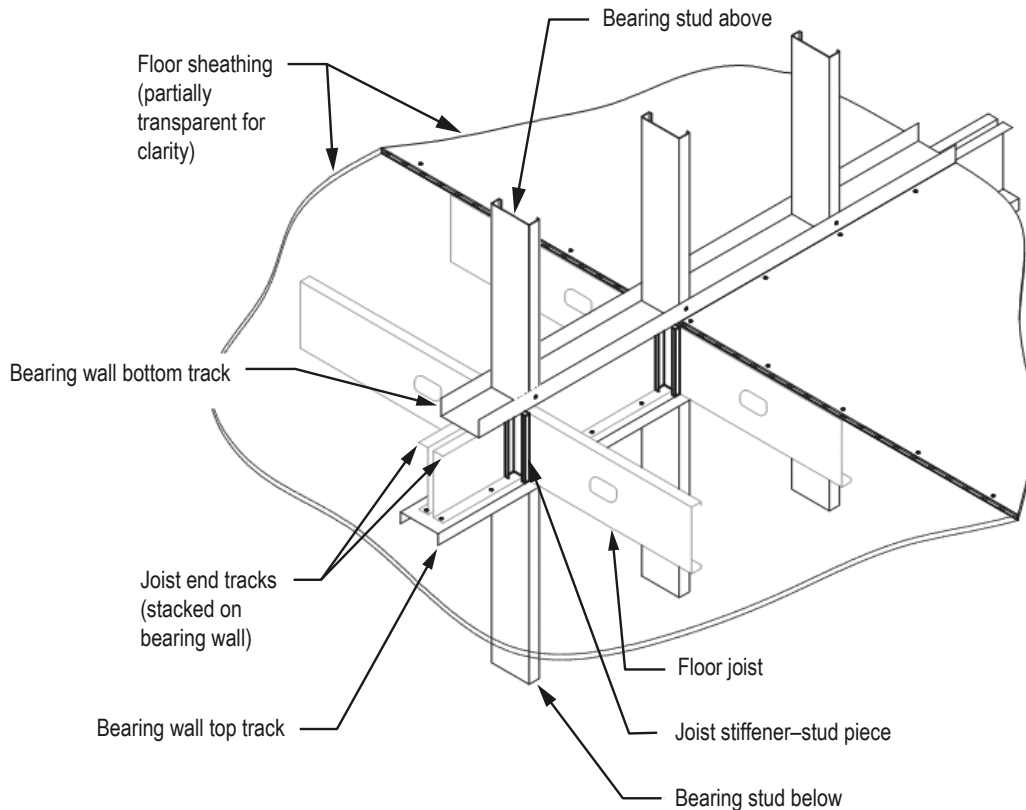


**Figure 3-2.** Basic CFS framing types.

Platform framing refers to a design where the joists run through the stud/joist intersection and the studs are interrupted by the joists. In this configuration, axial load from the upper stud is transferred through the floor joist web and web stiffener into the lower stud. The joist stiffener, as defined in **Figure 3-3**, must fit tightly into the inter-floor space or the reinforced web crippling capacity

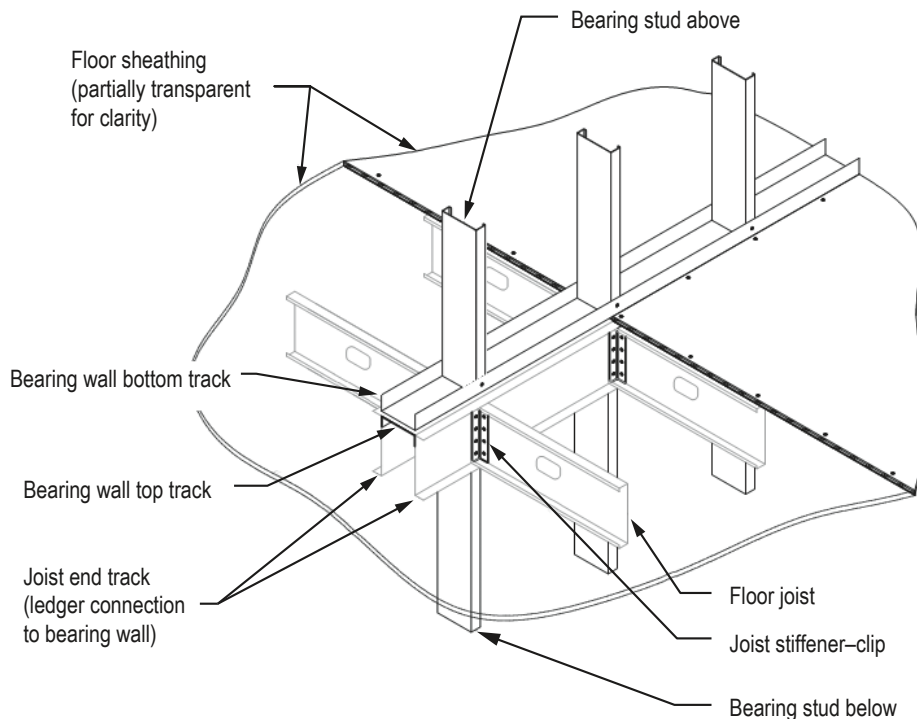
of the joist checked to preclude localized failure. The studs and joists are required to vertically align within tolerances noted in AISI S240-15. Refer to AISI Research Report RP03-6, *The Strength of Stiffened CFS Floor Joist Assemblies with Offset Loading* (AISI 2006). Top track or bottom track members can be upsized and designed to withstand the moments and shears developed should the members not align. This process would be necessary, and is common, when studs and joists or trusses, are at a different spacing. The typical platform framing configuration is shown in **Figure 3-3**.

Platform construction is common in cold-formed steel framing when the floor system uses steel joists and/or metal deck with concrete, hollow core panels, or other rigid floor panels. These floor systems are constructed separately from the CFS-framed walls, and this combination of components can be efficient as it provides clear separation in the construction elements (and potentially in the trades involved). The combination of non-CFS floor framing with CFS wall framing is also more forgiving with respect to tolerances between the systems.



**Figure 3-3.** Typical platform-framed construction.





**Figure 3-4.** Typical ledger framed construction.

Ledger framing (see **Figure 3-4**) is similar to wood frame balloon framing, the original framing system for light frame wood buildings, developed in the 1800s. Balloon framing, in which a two-story house was built using two-story-high studs, was once popular in timber construction when long timbers were readily available. In ledger framing, the CFS floor joists are hung from a ledger attached to the inside face of the wall, but the floor sheathing runs throughout the entire floor. Ledger framing provides for simple floor-by-floor construction, allows the wall stud spacing and the floor joist spacing to differ for maximum economy, and provides a direct path for the horizontal diaphragm forces into the vertical walls. However, the method is popular only when CFS joists are used for the floor framing.

In ledger framing, the studs run through the stud/joist intersection, and the joists are connected into a ledger at the face of the studs. Load from the joists are transferred to the ledger track either in direct bearing or via clip attachment. The ledger track is in turn screwed to the studs to complete the load path. Studs from above bear directly over studs from below. Load eccentricities from the transfer of forces from the ledger to the flange of the stud, rather than to the center of the stud, must be

considered. Where framing occurs on both sides of the stud wall, these eccentricities counteract one another; however, unbalanced loads may need to be considered. The moments caused by these eccentric loads are not cumulative from level-to-level but can be a significant portion of the total bending moment of the stud. Axial loads from studs above are concentric provided the studs are aligned. Studs and joists need not align in this configuration because of the ability of the ledger to distribute load.

Ledger framing tends to be employed for multiple-level structures because the axial loads in the studs increase with the number of levels and must be transferred through the stud/joist intersection at the floor levels. If a platform system is employed for such a structure, the joists typically require stiffeners to prevent web crippling caused by these axial loads.

Platform framing designs can be beneficial in panelized systems because of the increased tolerance for placing floor panels over the bearing walls rather than onto the side of the wall. The construction also allows the floor panels to be simply placed over the walls rather than held in place while the ledgers are connected.

### 3.3 A Comparison to Light-Framed Wood Construction

Both platform and ledger framing are used in timber framing systems. The design decisions on which system to use are similar. The exception is that in light-framed wood construction, shrinkage of wood members as moisture content reduces is a significant design consideration, whereas with CFS framing, there is no significant deformation over time.

Light-framed wood and CFS systems both use repetitive joists and studs assembled to form an effective overall structure. Floor and wall sheathing can also be similar. Most structural engineers starting to design with CFS framing will use details taken from wood framing and adapt them to CFS. There are, however, fundamental differences in the material used, including the following:

- Steel studs can be significantly stronger than wood and allow for increased spacing, up to 24 inches (610 mm) on center, even in multi-story structures. Stud thickness can be increased at lower, more highly loaded levels more economically than installing additional studs as may be required with wood framing.

- Steel stud connections can be significantly stronger and more compact than similar wood connections. Screw spacing in CFS can be very tight compared to nail spacing in wood, because with wood members, there is concern for splitting the wood. Welding of CFS for particularly critical components is also available.
- Boundary elements of shear walls are required to be designed for increased forces to preclude failure at inelastic seismic force levels. The resulting designs can have very large hold-down forces requiring a more robust solution for CFS than for wood-framed designs. Multi-story structures may require structural steel links and welding rather than screwed connections. **Figure 3-5** illustrates an example of this type of connection.
- Structural plans for CFS framing typically require a higher level of detailing because of a relative lack of the standard details that exist for wood-framed construction.
- Fire and sound ratings for CFS framing can be different than wood framing and in many cases can influence the structural details for a project. Some fire ratings will affect the allowable axial loads in rated bearing walls. Coordination with all design professionals at an early stage is required prior to final structural design.

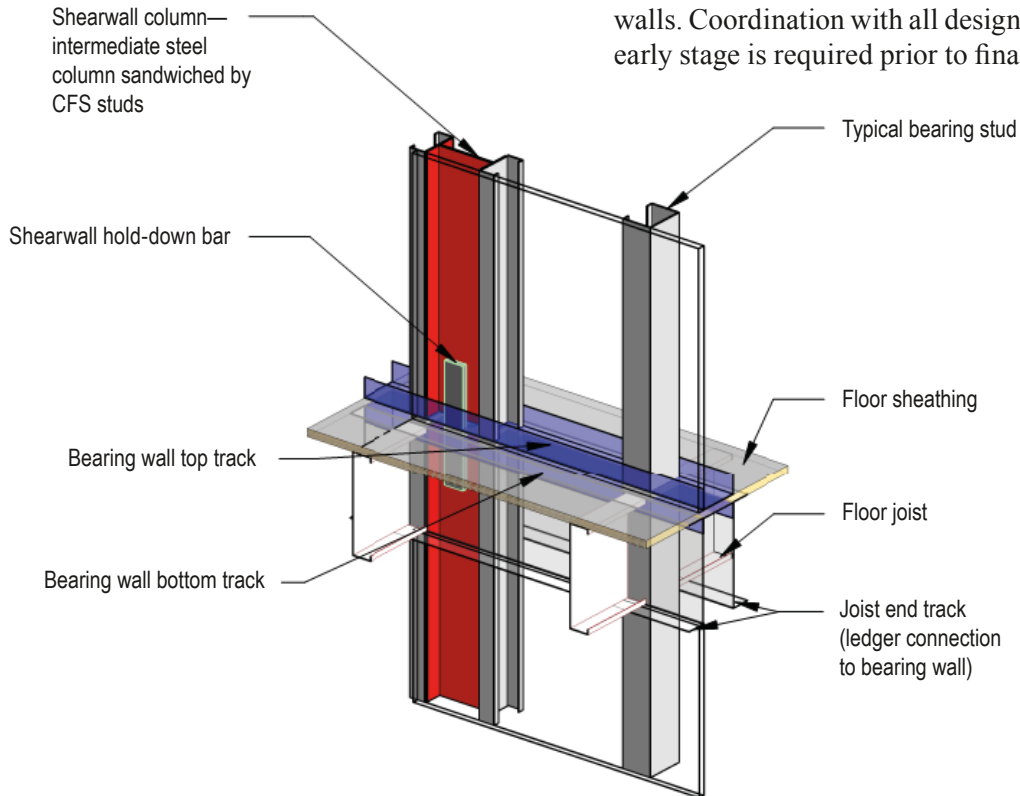


Figure 3-5. Example of floor to floor hold-down connection.

## 4. Seismic Force-Resisting Systems

### AISI S400-15

Most recent designs of CFS SFRSs have been based on AISI S213-07/S1-09. AISI S400-15 presents essentially the same requirements in a more easily understood fashion with a more consistent approach to the various systems. Because in the near future AISI S400-15 will be adopted as the required standard, the content here is based on AISI S400-15.

AISI S400-15 adopts the concept of capacity-based design. The required strength of elements of the LFRS that deliver seismic forces to the SFRS (e.g., collectors) and to the components of the SFRS that are not designated to dissipate energy (e.g., shear wall chords, hold-downs and anchorages) is based on the expected strength of the SFRS designated energy dissipating mechanism, but the strength needs not exceed the load effect including seismic Overstrength,  $\Omega_o$ , from the applicable building code.

For structures braced entirely by light-frame shear walls, ASCE 7 does not require that collector elements and their connections be designed for the expected strength of the SFRS or the load effect including seismic overstrength. However, the more stringent provisions of AISI S400-15 govern in this instance.

AISI S400-15 requires that the available strength of these capacity-protected elements and connections be adequate to resist these forces. This differs from other standards, including portions of AISI S213-07, which allow the design strength of certain elements and connections to be taken as the nominal strength.

The determination of expected strength for various SFRS is discussed in more detail below.

The design process for CFS SFRSs is similar to that used with other materials. A typical design of a CFS LFRS would be completed as follows:

1. Determine base and story shear forces per the applicable building code. For designs based on ASCE 7, the calculated base shears are dependent on the Response Modification Factor,  $R$ , which varies for the different SFRSs. Therefore, an initial selection of the type of SFRS is required for base shear determination.
2. Create a preliminary layout of the SFRS (e.g., shear walls or strap-braced walls).
3. Based on the preliminary layout, estimate the forces in the SFRS elements. (See the sidebar on the next page about guidelines for selecting an appropriate SFRS based on loading).
4. For shear walls, select the sheathing type and fastener pattern required to meet the required strengths. For strap-braced walls, determine a strap size and steel grade.
5. Size chord studs by considering overstrength or expected strength as required by AISI S400.
6. Size inter-story ties, hold-downs and anchors considering overstrength or expected strength as required by AISI S400.
7. Size shear connections at inter-story and foundation levels considering overstrength or expected strength as required by AISI S400.
8. Check story drift to ensure that requirements of the applicable building code are met. Adjust the design if necessary.
9. Design diaphragms, diaphragm chords, and collectors. While diaphragm and diaphragm chords are not required to be designed for overstrength or expected strength, collectors and collector splices are required to be designed for these higher loads.

## SFRS Selection

Determination of the most appropriate CFS SFRS for a given building includes both architectural and structural factors. Architecturally, the layout of the SFRS needs to comply with the intended use of the building and the architect's intent with regard to room size and location of openings. In addition, if the building is to be of noncombustible construction, wood structural panel shear walls may not be an appropriate choice.

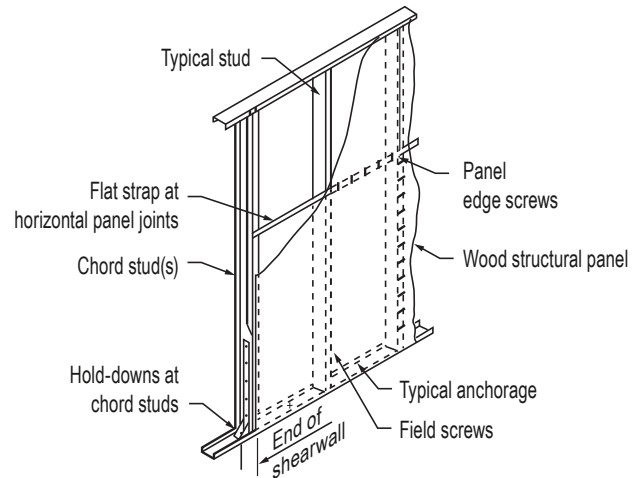
Structurally, the magnitude of the loads in each SFRS element and limits on aspect ratios will generally determine the SFRS selection. The following available strength and limiting aspect ratio guidelines can be used when selecting an SFRS:

- Shear walls with wood structural panels: 420 lb/ft to 1,848 lb/ft (6,130 N/m to 26,970 N/m) for panels on one side. These values can be doubled for identical sheathing and fasteners on both sides of the wall. Maximum aspect ratio is 4:1, depending on sheathing and fastening pattern.
- Shear walls with steel sheet sheathing:  $\phi v_n = 234$  lb/ft to 1,251 lb/ft (3,410 N/m to 18,260 N/m) for panels on one side. These values can be doubled for identical steel sheet and fasteners on both sides of the wall. Maximum aspect ratio is 4:1 depending on sheathing and fastening pattern.
- Strap-braced walls can be designed with a wide range of available strength by varying the strap width, thickness, and yield point. Aspect ratios greater than 4:1 can also be used. However, for aspect ratios greater than 1.9:1, the design must consider weak-axis bending moments in the chord studs. Anchorage forces for strap-braced walls often limit both the total available strength and aspect ratio.

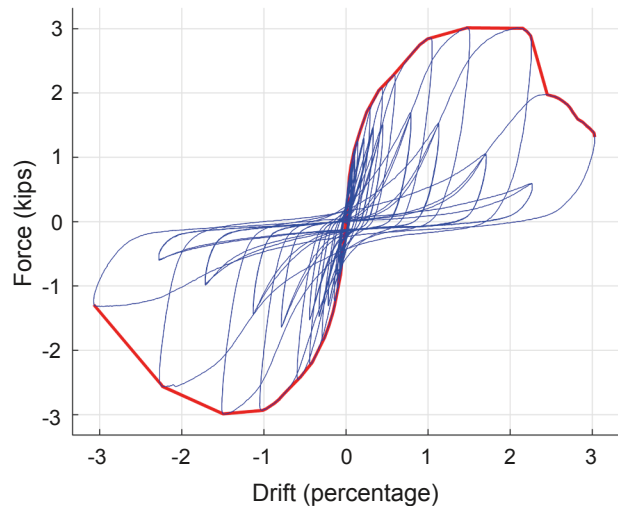
ASCE 7 specifies a *Response Modification Factor R*, of 6.5 for bearing wall systems with CFS shear walls using wood structural panels or steel sheet sheathing, and an *R* of 4 for bearing wall systems with CFS strap-braced walls. Therefore, the calculated base shear for shear walls is significantly lower than the base shear calculated for a similar structure using strap-braced walls.

## 4.1 Shear Walls Sheathed with Wood Structural Panels

Shear walls with wood structural panel (WSP) sheathing are one of the most common SFRS used with CFS framing (see **Figure 4-1**). A considerable body of research has confirmed that the primary energy dissipating mechanism for this system is deformation in the member-to-sheathing connections, along with additional energy dissipation in the wood panels themselves. Typical hysteretic behavior is shown in **Figure 4-2**.



**Figure 4-1.** Wood structural panel sheathed shear wall.



**Figure 4-2.** Hysteresis loop for wood structural panel sheathed shear wall, with backbone curve in red.

Fastening of wood structural panels to CFS framing is commonly accomplished with screws. Nominal shear strength of shear walls constructed in this manner is given in AISI S400-15 Table E1.3-1. However, other methods, including pneumatically installed “pins,” can be used. For these alternate systems, data from the fastener manufacturer must be used to determine shear strength, ability to dissipate energy, required framing thickness and maximum aspect ratio.

Shear strength data are provided in AISI S400-15 for Structural I sheathing and OSB with a variety of fastener spacing as well as stud and track thickness. To ensure adequate energy dissipation without fracturing screws, the stud and track thickness tabulated is not allowed to be increased unless the thickness is specified as “(min)” in the tables. Research has shown that thicker steel can limit the ability of the screws to articulate without fracture, thus limiting the ductile behavior of the system.

Because the energy dissipating mechanism is the panel-to-framing connection, using identical sheathing and fasteners on both sides of the wall doubles both the nominal shear strength and energy dissipating capacity of the system. Accordingly, AISI S400-15 allows the capacity of such systems to be doubled. However, sheathing or fastener spacing that is not identical on opposing sides of a wall may not provide the same load-deformation characteristics and, thus, the strength and energy dissipating ability of the two sides of the wall are not additive. In this case, AISI S400-15 considers two scenarios. The one with higher strength governs:

1. The weaker side fails first, and it is assumed that the stronger side can contribute at least as much strength as the weaker side. The total capacity can then be based on a shear wall assuming the weaker assembly on both sides.
2. The weaker side fails and the stronger side resists the entire applied load. On this basis, the strength of the weaker side is ignored, and the total capacity can be based on the stronger side.

When considering shear walls with sheathing on both sides of the wall, forces on chord studs, anchors, hold-downs, and collectors should be based on the same procedure described above to determine the shear wall nominal strength and include the expected strength factor,  $\Omega_E$ , from AISI S400-15 §E1.3.3 or overstrength factor  $\Omega_o$ , from ASCE 7 Table 12.2-1.

AISI S400-15 tabulates shear strength for shear walls with an aspect ratio of 2:1. However, based on available research, for certain assemblies the allowable aspect ratio can be as high as 4:1. For these cases, the nominal shear strength of the shear wall is reduced per AISI S400-15 Equation E2.3.1.1-2.

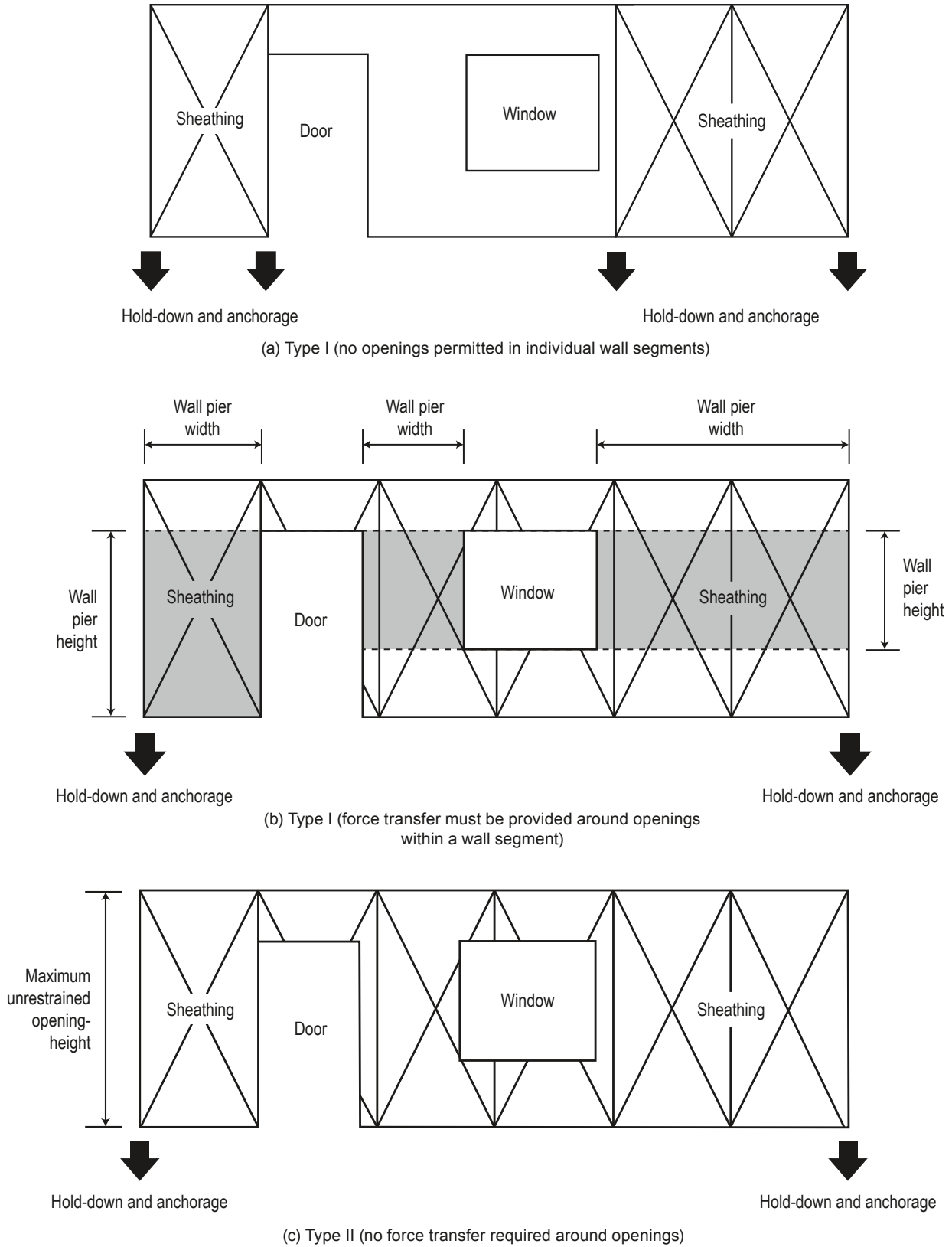
CFS shear walls with wood structural panels require all sheathing edges to be attached to framing members or panel blocking. Panel blocking is used to transfer shear between adjacent panels. Minimum 0.033 inch (0.84 mm) thick flat strap (see **Figure 4-1**) is an acceptable form of panel blocking for this purpose. Flat strap blocking by itself will not provide rotational restraint to the studs. Separate bridging or stud-blocking may be required where wall studs or chord studs require rotational restraint to support flexural or axial loads.

AISI S400-15 provides design requirements for Type I and Type II shear walls with wood structural panels. Type I shear walls are fully sheathed with hold-downs at each end but are allowed to have openings where detailing is provided for force transfer around the openings. **Figure 4-3(a)** shows a Type I shear wall with no openings within each wall segment. Where Type I shear walls are provided with force transfer details around openings, each wall pier, as shown in **Figure 4-3(b)**, must meet the minimum width and maximum aspect ratio requirements of AISI S400-15. Type II shear walls, as depicted in **Figure 4-3(c)**, are allowed to have openings without specific details for force transfer around openings and use a shear resistance adjustment factor,  $C_a$ , based on the maximum height of openings and the percent of full-height sheathing. In addition to hold-downs at each end of a Type II shear wall, anchorage is required at the full-height sheathing locations between the ends of the shear wall capable of resisting a uniform uplift force equal to the unit shear force in the wall. This requirement can make the cost effectiveness of Type II shear walls questionable.

#### Type II CFS Shear Walls

Type II CFS shear walls are similar in concept to perforated wood-framed shear walls. Guidance for estimating deflection of perforated wood-framed shear walls can be found in ANSI/AWC SDPWS-2015. *Special Design Provisions for Wind & Seismic* (ANSI/AWC 2015). This method uses the same basic equation specified for wood-framed nonperforated shear walls with adjustments to the applied unit shear and shear wall length based on the type and size of perforations.





**Figure 4-3.** Type I and Type II shear walls.

Expected strength of CFS-wood structural panel shear walls is subject to uncertainties that include variability in materials and construction techniques. AISI S400-15 accounts for this uncertainty by estimating expected strength as the nominal shear strength multiplied by the overstrength factor,  $\Omega_o$ , from ASCE/SEI 7-10.

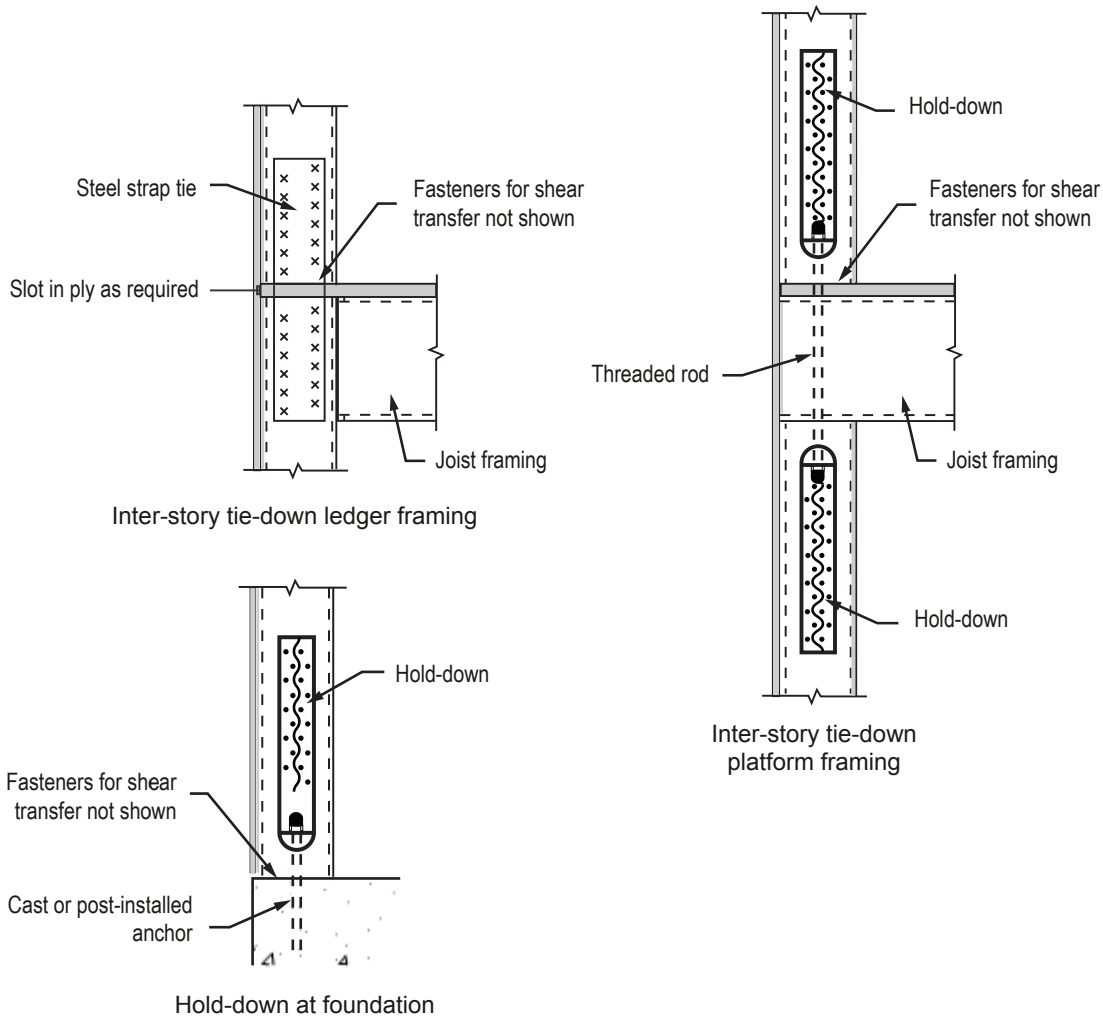
**Future Versions of AISI S400 and  $\Omega_E$**

It is anticipated that future versions of AISI S400 will provide more rational values of  $\Omega_E$  for shear walls. A ballot being developed for consideration by the AISI Committee on Framing Standards (COFS), Lateral Subcommittee would set  $\Omega_E = 1.8$ . The rationale for this value is described in Section 7.

The design of chords, collectors, and anchorages is discussed above and applies to CFS-wood structural panel shear walls. Shear wall chord studs are typically designed

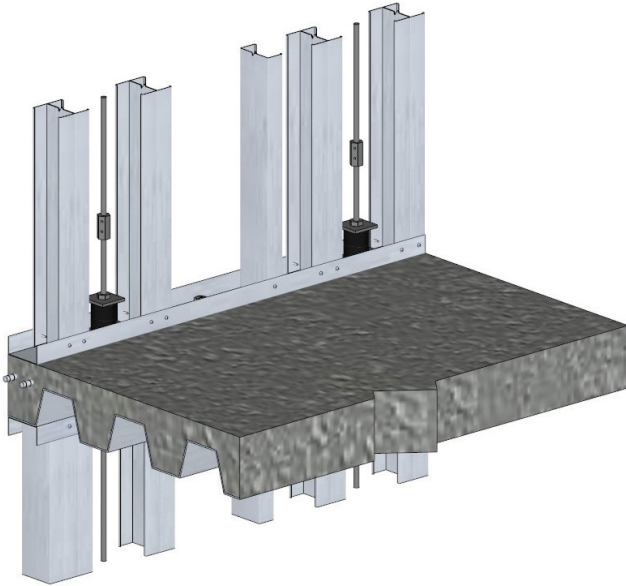
as single, boxed, or back-to-back C-studs depending on demand. The maximum thickness of chords needs to adhere to the limitations of the tabulated assembly to ensure ductile behavior. Chord stud available strength can be determined using AISI S100-12. Boxed and back-to-back chords, unless treated as two separate, individual sections, require specific interconnection design specified in AISI S100-12 §D1.2. These requirements use a modified radius of gyration for calculating buckling loads and include requirements for the spacing and strength of interconnections.

A variety of hold-down and anchorage types are available. Bracket type hold-downs with cast-in-place or post-installed (mechanical or adhesive) anchors have been used to anchor shear walls to foundations. Similar systems have also been used to transfer vertical shear wall forces between floors. **Figure 4-4** shows examples of traditional hold-downs and inter-story tie-downs.



**Figure 4-4.** Inter-story tie-down and hold-down examples.

Continuous rod tie-down systems (see **Figure 4-5**) are becoming more common, particularly in mid-rise construction. These systems provide a continuous load path for tension forces developed in the SFRS and offer higher tension capacities than traditional hold-downs.



**Figure 4-5.** Continuous rod tie-down system.

AISI S400-15 provides a method for determining the deflection of Type I shear walls with wood structural panels. The method includes deflections attributed to cantilever bending (axial deformation of the chords), shear deformations in the wood structural panels, and hold-down deformation. An empirical, nonlinear term is also included based on research. The nonlinear term accounts for deflections because of deformations at fasteners and other sources not otherwise explicitly included in the calculation. For most shear walls, the vast majority of the deformations are due to the nonlinear term and deformations at the hold-downs. Deflection of Type II shear walls requires a rational analysis, including the deformation contributions of sheathing and its attachment, chord studs, hold-downs, and anchorage.

#### **4.2 Shear Walls Sheathed with Steel Sheet Sheathing**

Shear walls can also be constructed with steel sheet over cold-formed steel framing. This construction offers good shear resistance in addition to being noncombustible. Nominal shear strength values are published in AISI S400-15, Table E2.3-1 for steel sheets with a thickness of 0.018 inch to 0.033 inch (0.46 mm to 0.84 mm) with

various screw spacing and framing thickness. Additional research is underway to expand the available data to thicker steel sheets and framing members. In future codes, this research should enable higher strength shear walls for use in mid-rise construction.

Steel sheet sheathed shear walls dissipate seismic energy primarily through the structural member-to-sheathing connection and yielding of the steel sheet. The basis of design, including the determination of expected strength and requirements for the design of chord studs, anchorage, and collectors matches the procedures for wood structural panel shear walls. Methods for both Type I and Type II shear walls are included as well. Hold-downs and inter-story tie-downs common to wood structural panel shear walls can also be implemented in steel sheet shear walls.

Similar to shear walls with wood structural panels, steel sheet shear walls are required by AISI S400-15 §E2.4.1.1 to have all sheathing edges fastened to structural members or panel blocking. AISI S400-15 allows lapping of adjacent sheets in lieu of panel blocking. However, the nominal shear strength of assemblies using this method of construction is reduced to 70 percent of the tabulated nominal shear strength.

In addition to tabulated shear values for specific assemblies, AISI S400-15 §E2.3.1.1.1 includes an effective strip method for steel sheet shear walls that allows calculations of nominal shear strength. The method uses the geometry of the wall, structural parameters of the framing and sheathing, and the fastener shear strength to calculate nominal shear strength. The method includes the same limitations on steel thickness and fastener spacing as the tabulated shear values, but does offer a wider range of options for walls with aspect ratios up to 4:1. This method is based on recent research (Yenaga and Yu 2014) and was not included in earlier codes and standards.

Deflection of Type I steel sheet sheathed shear walls uses the same basic procedure used for wood structural panel shear walls. Similarly, deflection of Type II steel sheet sheathed shear walls requires a detailed rational analysis.

#### **4.3 Strap Braced Wall Systems**

Strap-braced walls, also called tension-only or X-braced walls, are another commonly used SFRS in CFS light frame construction. Strap braced walls with very high lateral strength can be designed by using relatively wide, thick straps. Structural shapes may also be used in place

of CFS stud framing at chord locations where warranted by the design loads.

The Response Modification Coefficient,  $R$ , Overstrength Factor,  $\Omega_o$ , and Deflection Amplification Factor,  $C_d$ , for CFS strap-braced wall systems differ significantly from those for CFS wood structural panel or steel sheet shear walls in Table 12.2-1 of ASCE 7. For CFS bearing wall systems with strap-braced walls,  $R = 4$ ,  $\Omega_o = 2$  and  $C_d = 3.5$ , compared with  $R = 6 \frac{1}{2}$ ,  $\Omega_o = 3$  and  $C_d = 4$  for CFS bearing wall systems with wood structural panel or steel sheet shear walls.

Implementation of capacity-based design to strap-braced wall systems is straightforward because the energy dissipating mechanism is yielding of the tension straps and the expected strength of the straps is well understood. The expected strength of the strap is determined from the expected strap yield point,  $R_y F_y$ , and the gross cross-sectional area.

To ensure that net section fracture of the tension straps does not occur prior to yielding of the strap gross cross-section, AISI S400-15 §E3.4.1(a) places specific limitations on the strap connections. Three methods for demonstrating compliance with these requirements are allowed: (1) the connection can be welded in a configuration ensuring yielding of the gross cross-section of the strap; (2) the connection can be configured such that  $(R_t F_u)/(R_y F_y) \geq 1.2$  and  $R_t A_n F_u > R_y A_g F_y$ , where  $R_y$  and  $R_t$  are expected strength factors for  $F_y$  and  $F_u$  respectively,  $A_n$  is the strap net cross-sectional area, and  $A_g$  is the strap gross cross-sectional area; or (3) the connection can be made in such a way that gross cross-section yielding of the strap under cyclic load is demonstrated by test. Not surprisingly, tests have shown that straps using a reduced section away from end connections can be useful in meeting the above requirements.

Consistent with other cold-formed steel SFRS, chord studs, collectors, and anchorages are required to be designed for the expected strength of the strap-braced walls. The strap connections must also be designed for the strap expected strength to ensure that the designated energy dissipating mechanism, strap yielding, can be activated prior to any other limit state being realized.

Strap-braced walls can generally be designed using principles of mechanics. However, experimental research has been conducted on strap-braced walls with high

aspect ratios to investigate the effect of joint rigidity on system performance (Mirzaei et al., 2015). This research has shown that strap-braced walls with aspect ratios exceeding 1.9:1 can generate significant moment in the chord studs at the strap connection location. The moment is a result of joint fixity inherent in typical strap connections. While AISI S213-07 simply limited the aspect ratio of strap-braced walls to 2:1, AISI S400-15 provides a method for designing to higher aspect ratios by performing a frame analysis that accounts for the joint fixity in the design of the chord studs. When sizing chord studs of high aspect ratio strap-braced walls, the weak-axis moment is based on forces derived from the strap expected strength. **Figure 4-6** illustrates rigid frame behavior observed in testing of strap-braced walls with high aspect ratios.



**Figure 4-6.** Narrow strap-braced wall.

Strap-braced walls can use straps on one or both sides. Straps used on one side of a wall can cause significant eccentric moment in the chord studs that must be included in their design. Chord studs in single-sided strap-braced walls of high aspect ratio are subject to compression, weak-axis bending, and strong-axis bending, all of which need to include consideration of the expected strength of the strap.

In addition to the concentrated vertical forces required for design of chords and hold-downs, the design of strap-braced walls must consider concentrated shear forces because of the horizontal component of the strap tension. If these forces are not transferred directly to the foundation or supporting structure at the location of the strap connection, the wall track must be designed to distribute the forces along some designated length via tension or compression in the track. Special detailing is required to ensure that the track can accommodate and transfer these loads.

Deflection of strap-braced walls can be determined from principles of mechanics but must account for deformation of the straps, chord studs, hold-downs, and anchorages. For strap-braced walls with aspect ratios exceeding 1.9:1, the analysis should also include the effect of joint fixity. Deflections accounting for each of these items can be determined from structural analysis software or by using closed-form equations presented in the AISI S400-15 commentary.

#### **4.4 Proprietary and Alternative Seismic Force-Resisting Systems**

Neither ASCE 7 nor AISI S400-15 limits acceptable SFRS to those specifically described within the standards. AISI S400-15, §H, indicates that substitute components and connections are allowable per the applicable building code. ASCE 7 allows alternate systems provided it can be shown that their dynamic strength and ability to dissipate energy are equivalent to a listed system having the same Response Modification factor, Overstrength factor, and Deflection Amplification factor.

##### **Anticipated Changes in ASCE/SEI 7-16**

It is anticipated that ASCE/SEI 7-16, *Minimum Design Loads and Associated Criteria for Buildings and Other Structures* (ASCE 2016), will include modified provisions for Alternative Structural Systems and Substitute Elements. The revised provisions will likely include more detailed requirements regarding how substitute elements are to be evaluated, documented, and specified. The provisions require that experimental evidence be submitted to the authority having jurisdiction showing that the proposed substitute elements provide similar strength and stiffness characteristics to one of the listed systems in ASCE 7 Table 12.2-1 when subject to the risk-targeted maximum considered earthquake ( $MCE_R$ ) ground motion.

The basic design philosophy of structures using an alternate SFRS matches that described above for listed systems. Accordingly, knowledge of the energy dissipating mechanism of these systems is critical to ensure that the mechanism can be protected. The necessary energy dissipation protection is achieved by designing other elements in the seismic load path for the expected strength of the SFRS or for the calculated forces, including the seismic Overstrength factor.

Technical data for proprietary SFRS may not include expected strength. If expected strength data are not available, chord studs, collectors, anchorages, and connections that resist or deliver forces to the SFRS should be designed for seismic forces, including the Overstrength factor,  $\Omega_o$ .

Other requirements such as structural system limiting heights comparable to those listed in ASCE 7 Table 12.2-1, aspect ratio, and any special detailing requirements necessary to ensure that the strength, stiffness, and energy dissipating characteristics of the SFRS, must also be considered. For proprietary systems, information regarding these special requirements should be provided by the manufacturer.



## 5. Diaphragms

Diaphragms used as part of CFS LFRSs are commonly constructed using sheathing or panels over repetitive cold-formed joists or trusses. Panels or deck may also be designed to span between bearing walls, eliminating the need for joists or trusses. Although it is generally accepted that diaphragms have some ability to dissipate seismic energy, the magnitude and nature of the energy dissipation are not well understood. Therefore, the philosophy in AISI S400-15 assumes diaphragms are not energy dissipating mechanisms for design purposes.

In accordance with AISI S400-15, diaphragms and diaphragm chords are designed for loads determined by the applicable building code and are not required to consider expected strength or overstrength. Diaphragm collectors, including connections and splices, are required to be designed for the expected strength of the SFRS or the calculated seismic forces, including overstrength.

The force distribution within the diaphragm and in chords and collectors is dependent on the stiffness of the diaphragm. The diaphragm must be designated as rigid, semirigid, or flexible depending on the stiffness of the assembly and the limits set forth in the applicable code for each category. However, for many CFS diaphragms, comprehensive stiffness data may not be available. One method to deal with this uncertainty is to analyze the system based on both rigid and flexible assumptions and design for the more conservative of the two.

### 5.1 Wood Structural Panels over CFS Framing

Diaphragms constructed of wood structural panels over CFS framing are popular because of the availability of materials, ease of installation, and readily accessible design data. AISI S400-15 includes specific strength and stiffness provisions for this system. Requirements are also prescribed relative to the thickness and spacing of framing members, diaphragm aspect ratio, and when  $R$  is greater than 3, specific dimensional limitations for open front structures.

The nominal shear strength for a variety of assemblies, presented in AISI S400-15, Table F2.4-1, is based on the type and thickness of sheathing, fastener spacing,

and whether the diaphragm is blocked or unblocked. Similar to shear walls, panel blocking consisting of steel flat strap to transfer shear between panels may be used in diaphragms in lieu of stud blocking. Where used as panel blocking, flat strap must be installed below the sheathing in accordance with AISI S400-15 §F2.4.1.1

ASCE 7 allows diaphragms of untopped steel deck or wood structural panels to be idealized as flexible for a variety of common structures, including certain types of light-frame construction. Where allowed, this assumption can ease the design effort considerably.

The full-scale, multi-story shake table testing performed as part of the CFS-NEES (Network for Earthquake Engineering Simulation) effort provided interesting insights into diaphragm stiffness (see Section 11).

A method for estimating the stiffness of wood structural panels over CFS framing diaphragms was included in AISI S213-07 but was moved to the commentary of AISI S400-15. Comparison of the tested diaphragm displacements from CFS-NEES to displacements predicted using this method shows the method to provide reasonable estimates of stiffness.

### 5.2 Metal Deck over CFS Framing

Metal deck diaphragms both with and without concrete fill are also used over cold-formed steel framing. AISI S310-13, *North American Standard for the Design of Profiled Steel Diaphragm Panels* (AISI 2013a) provides methods for determining the strength and stiffness of steel diaphragm panels, including panels with concrete fill, and the strength and stiffness of common diaphragm connections. However, AISI S310-13 does not provide guidance on design of complete diaphragm systems or tabulated design values for any particular assembly. Specifying values for these systems requires considerable effort on the part of the designer.

As always, in addition to the design of the diaphragm membrane, the design and detailing of chords and collectors must provide for load transfer from the diaphragms to the SFRS.

### **Changes in AISI S310-16**

AISI S310-16 (AISI 2016b) will include minor modifications to the available diaphragm strength. The changes are based on new equations for screw strength that provide reduced nominal strength of the connection but a higher reliability index, which results in lower safety factors and higher resistance factors.

### **5.3 Concrete-Filled Deck and Concrete Planks**

Concrete-filled deck and concrete plank floor systems are also used in CFS construction and may be supported directly by CFS load-bearing walls without repetitive joist or truss framing. The weight of these systems increases seismic demands considerably. In addition, this type of system does not comply with the definition of light-frame construction provided in Chapter 2 of the 2015 *International Building Code* (ICC 2015). Therefore, careful consideration should be given to the selection of the SFRS for this type of structure. See IBC SEAOC *Structural/Seismic Design Manual* (SEAOC 2012), Volume 2, Example 3 for additional discussion.

## 6. Cyclic Performance of CFS Seismic Force-Resisting Systems

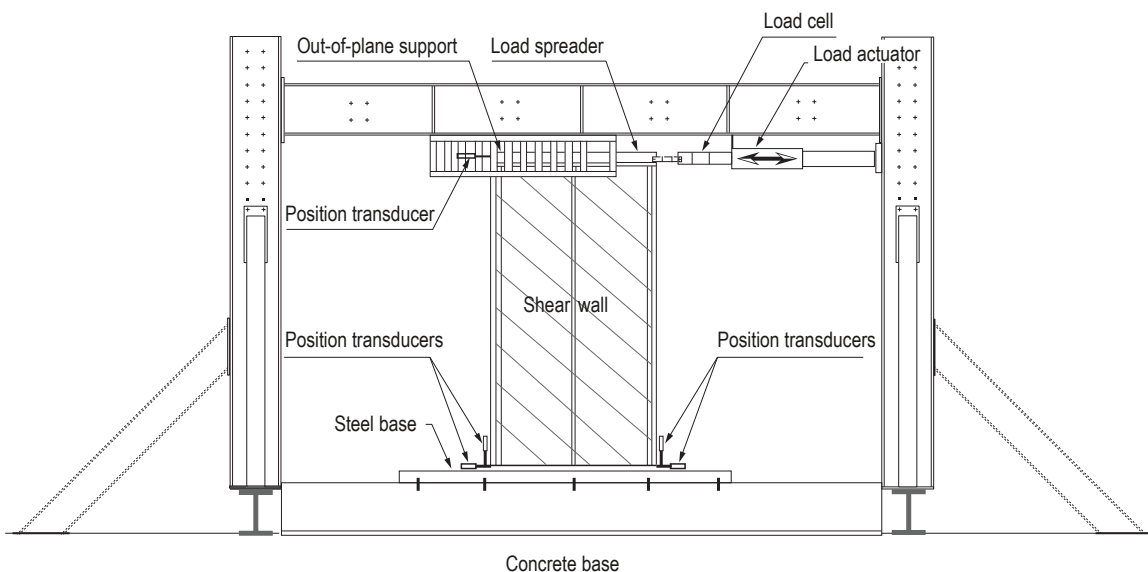
This section discusses the results of laboratory testing of CFS SFRSs, complete CFS-framed buildings, and components of these systems.

### 6.1 Hysteretic Behavior of Walls

As introduced in Section 2 of this Guide, the hysteretic performance of cold-formed steel framed shear walls has been largely established by testing. Typically, individual, single-story, cold-formed steel-framed shear walls are tested under conditions similar to those shown in **Figure 6-1**. The shear walls are connected at their base with hold-downs, ties, and shear anchors consistent with typical installed conditions, and the top of the wall is connected to a loading apparatus that is braced out of the plane of the wall and supplies the lateral (shear) demand. The top condition idealizes the diaphragm, and most testing is conducted with lateral loads only (i.e., no superimposed gravity load). Nonetheless, gravity loads must be considered in design. Both monotonic (pushover) and cyclic testing are conducted, most commonly to ASTM E564 (ASTM 2006) and ASTM E2126 (ASTM 2011) respectively. The cyclic loading protocol has evolved since the late 1990s when testing on cold-formed steel framed shear walls was first conducted primarily to the sequential phase displacement (SPD) protocol. Most testing now follows the CUREE loading protocol (Krawinkler et al. 2000).

The observed response of typical CFS shear walls is provided in **Figure 6-2** and **Figure 6-3**. Although the behavior of CFS seismic force-resisting systems, such as WSP shear walls, steel sheet shear walls, and strap-braced walls, is ostensibly quite different, their gross shear force-deformation response shares certain similarities. **Figure 6-3** provides typical hysteretic response for available test data on 4 feet by 8 feet (1.23 m by 2.46 m) shear walls at the light and heavy ends of the tested spectrum for the three most common CFS SFRSs. Significant pinching in the hysteretic response is a common feature.

The source of the pinching in the hysteretic response is different in each of the major CFS SFRSs even if the effect is the same. For the WSP shear walls, the damage done in the WSP during the bearing of the fastener against the panel and the gap left as the fastener pivots back to the other side in load reversal is the primary source for pinching. For the steel sheet shear wall, when loaded in one direction, a tension field forms in the sheet, but when the wall is deformed in the opposite direction, a compression buckle forms at the same location. During load reversal, the compression buckle must be stretched back to straight before picking up load, leading to the strong pinching observed. In addition, for steel sheet shear walls, bearing deformations at the fastener location similar to the WSP shear wall also occur. Finally, strap-braced walls are most similar to steel sheet shear walls,



**Figure 6-1.** Example of shear wall testing rig, based on Liu et al. (2012).

but with only a single tension field and single compression buckle; otherwise, the phenomenon in load reversal is similar. Depending on how the straps are connected, bearing deformations at the end fasteners may also occur. Additional design considerations for CFS strap-braced walls have recently been published in ERDC/CERL TR-15-16, *Development of Cold-Formed Steel Seismic Design Recommendations* (US Army Corps of Engineers 2015).

It is common to provide shear wall capacities in terms of pounds per lineal foot (plf) as opposed to the absolute

shear capacity. (For example, see tables in AISI S400-15, which are based on tested capacities.) The example shear walls in **Figure 6-3** range on the “light” end from 750-1,000 plf (11,000 N/m to 15,000 N/m) to approximately 2,000 plf (29,000 N/m) on the “heavy” end. AISI S400-15 provides strength in tabular form and expressions for predicting deflection. The AISI S400-15 deflection predictions provide an estimate of the drift up to the peak load, but not beyond. The complete deflection capacity (i.e. drift limit) of CFS SFRS shear walls is not generally summarized or available.



(a) Typical one-sided specimen in test rig (adapted from Hikita 2006 Figure 4-11)



(b) Example of pull-through and edge tear-out at end of test (adapted from Hikita 2006 Figure 4-24)



(c) Typical strap-braced wall specimen in test rig (adapted from Comeau 2008 Figure 2.21)



(d) Strap-braced wall after testing, showing yielding in strap (adapted from Comeau 2008 Figure 2.23)

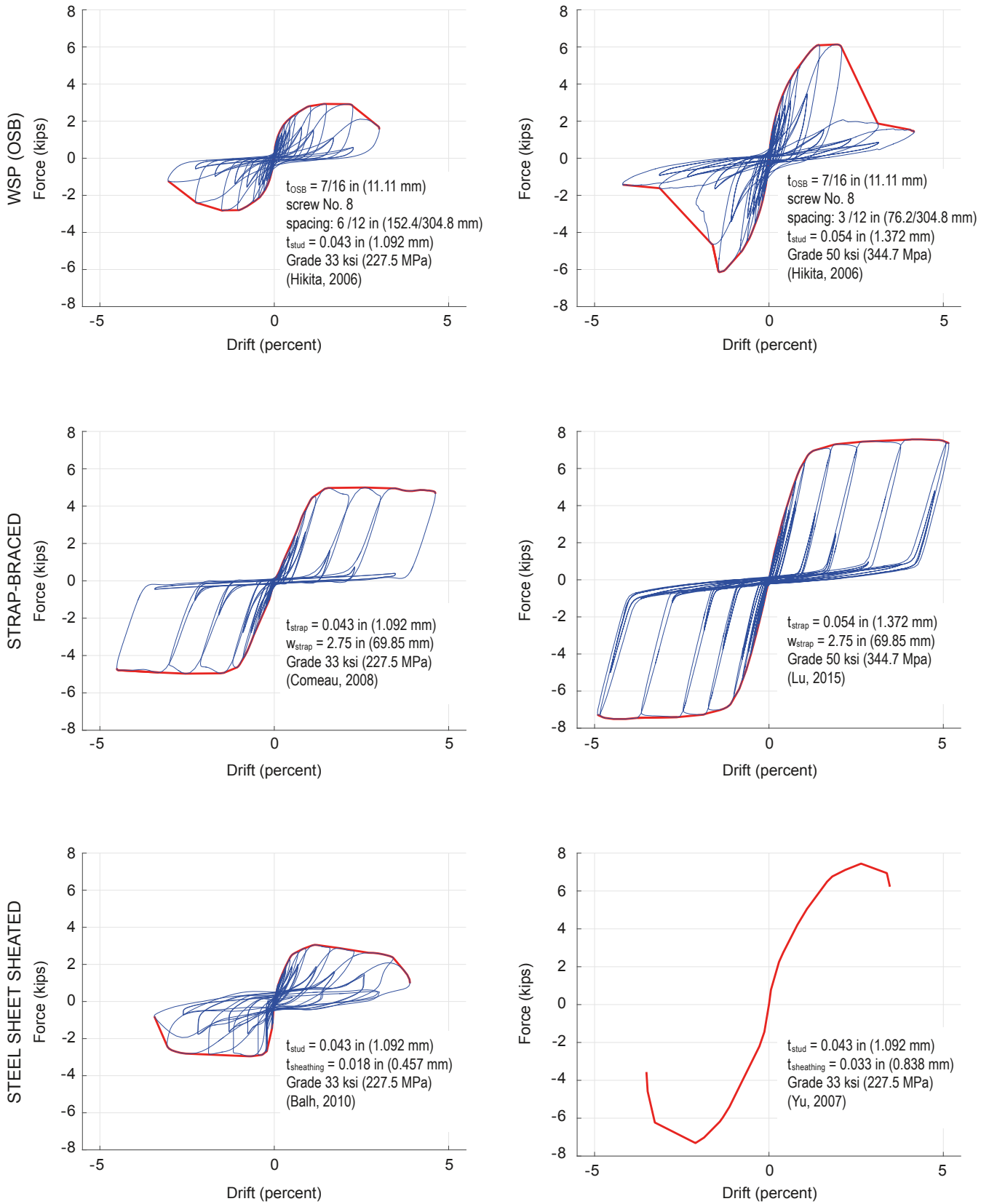


(e) Typical one-sided steel sheet sheathed specimen in test rig (adapted from Balh and Rogers 2010 Figure 2.17)



(f) Steel sheet shear wall exhibiting shear buckling during testing (adapted from Balh and Rogers 2010 Figure 2.18)

**Figure 6-2.** Observed response of common cold-formed steel framed shear walls under cyclic loading to failure.



**Figure 6-3.** Hysteretic response recorded in typical cyclic shear wall testing for the spectrum of tests (where  $t$  is the thickness,  $w$  is the width). Note, complete hysteretic response for the “heavy” example, steel sheet sheathed shear wall, is available in Yu et al. (2007); the authors have digitized and provided the backbone response only in this figure.



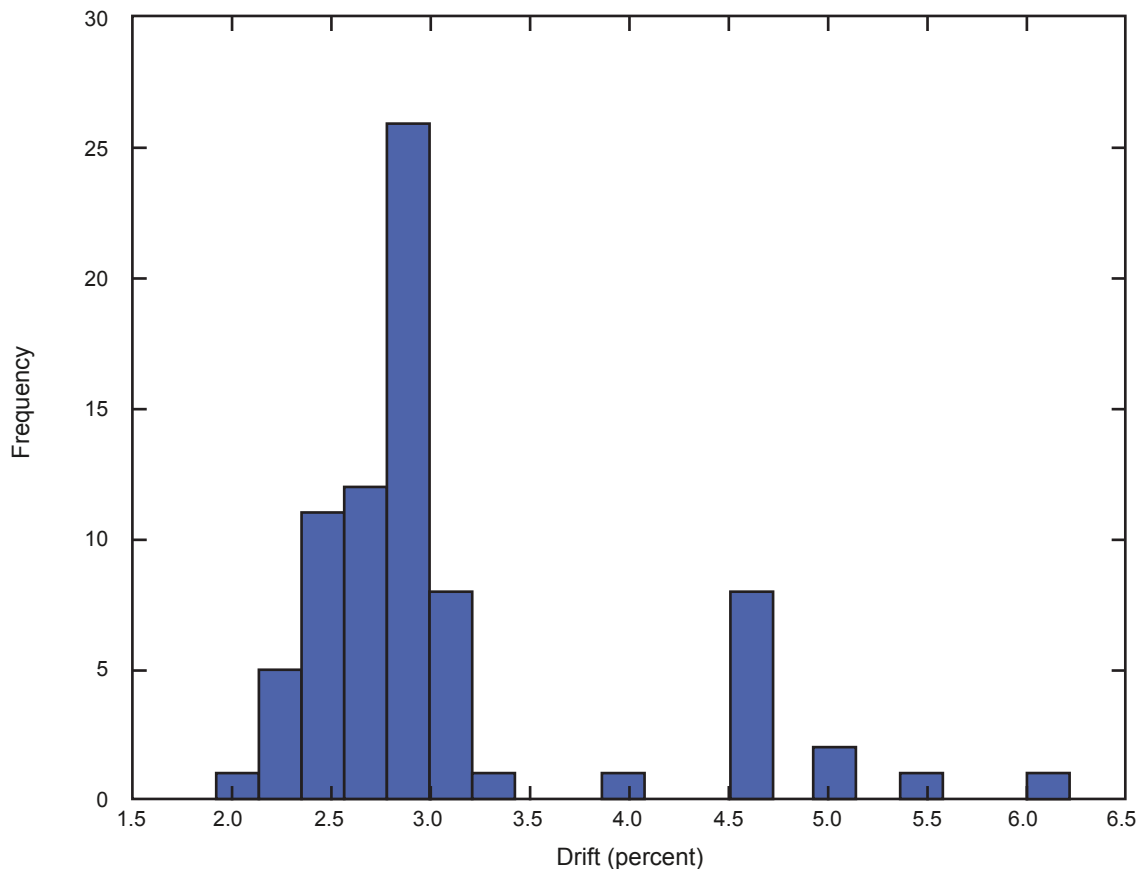
As part of an effort to provide updated provisions for the next version of ASCE 41, a database of all available shear wall tests was recently compiled (Ayhan et al. 2016). As of spring 2016 the database consisted of testing from the following reports: Al-Kharat and Rogers (2005, 2006), Balh and Rogers (2010), Blais (2006), Boudreault (2005), Branston (2004), Chang (2004), Comeau (2008), DaBreo (2012), Elhajj (2005), El-Saloussy (2010), Hikita (2006), Kochkin and Hill (2006), Liu et al. (2012), Lu (2015), Morello (2009), Ong-Tone (2009), Rokas (2006), Serrette et al. (1997a), Shamin (2012), Velchev (2008), Yu and Chen (2009), Yu et al. (2007), and Zhao and Rogers (2002). As an example, the observed drift limit across the 77 available tests conducted with cold-formed steel framing and OSB panels is provided in the histogram of **Figure 6-4**. The mean drift limit is 3 percent, but observations as low as 2 percent and as high as 6 percent exist. The mean drift at peak load and mean maximum drift across the available testing are summarized in **Table 6-1**. Substantial variation exists across the testing, but a

Drift Capacities			
	Mean Drift at Peak Load ( $\Delta/h$ ) percent	Mean Drift Limit ( $\Delta/h$ ) percent	Tests
WSP			
OSB	2	3	77
DFP*	2½	4	26
Steel Sheet	2	3	177
Strap-braced	4½	5½	77

\* DFP = Douglas Fir Plywood, similar to Structural I

**Table 6-1.** Summary of average drift capacity in tested CFS SFRSs.

maximum drift in the range of 3 to 4 percent is typically recorded in CFS-framed sheathed shear wall tests and up to 5½ percent for CFS-framed strap-braced walls.



**Figure 6-4.** Histogram of observed drift limit for tested cold-formed steel framed OSB sheathed shear walls.

## 6.2 System Performance: CFS-NEES Research Program

This section discusses the system performance of buildings framed from cold-formed steel as documented in the CFS-NEES research program. The complete research program, which consisted of modeling and testing across scales from individual fastener to the complete building is detailed at [www.ce.jhu.edu/cfsnees](http://www.ce.jhu.edu/cfsnees) and summarized in Schafer et al. (2016).

### 6.2.1 Building Characteristics (Stiffness, Damping)

Although testing on CFS shear walls and other SFRSs is relatively extensive, testing on complete CFS buildings is limited, with the CFS-NEES testing providing the only benchmark for a complete building. Technical summaries of the CFS-NEES testing (Peterman 2014, Peterman et al. 2016) and the data (Peterman et al. 2014) are available. The testing involved system identification and seismic simulation on a two-story ledger-framed CFS building that employed WSP (OSB) for the shear walls and the floor and roof diaphragm. The testing was conducted in two major phases. In Phase 1 (see **Figure 6-5a**), only the structural systems were considered, and tests were conducted up to and including earthquake records consistent with a design basis earthquake for southern California. In Phase 2, a nominally identical building was constructed, and system identification was completed for construction phases beyond the structural-only system,

including Phase 2b, which added exterior sheathing to all perimeter walls; Phase 2c, which added interior gypsum to all perimeter walls; Phase 2d, which added all interior partitions; and Phase 2e (**Figure 6-5b**), which added an exterior finish. Mass for the building was maintained at the full design load and held constant by removing mass as additional building elements were added. In Phase 2, the building was tested with earthquake records consistent with the design basis and maximum considered earthquake for southern California.

The stiffness of the building increases significantly as construction phases are completed in a typical CFS structure. **Figure 6-6** provides the first period of vibration in the long and short directions for the two-story building as a function of phase of construction. The Phase 1/Phase 2a building (CFS-NEES Test Phase 1 and Phase 2a are nominally the same) has a period of approximately 0.35 seconds, the tested fundamental period of vibration of the structure. The building is far stiffer than what would be calculated using the stiffness provisions for the shear walls in AISI S400-15, even for the bare system (Leng 2015). The long direction of the building, which has a significant amount of unsheathed wall studs in the “structural-only” Phase 2a, sees the greatest decrease in period (increase in stiffness). The long direction period decreases from 0.32 seconds to 0.15 seconds. The constant mass indicates that the stiffness is 4.5 times greater. Even in the short direction, which is largely shear walls, stiffness increased by a factor of 1.9 from Phase 1/Phase 2a to Phase 2e.

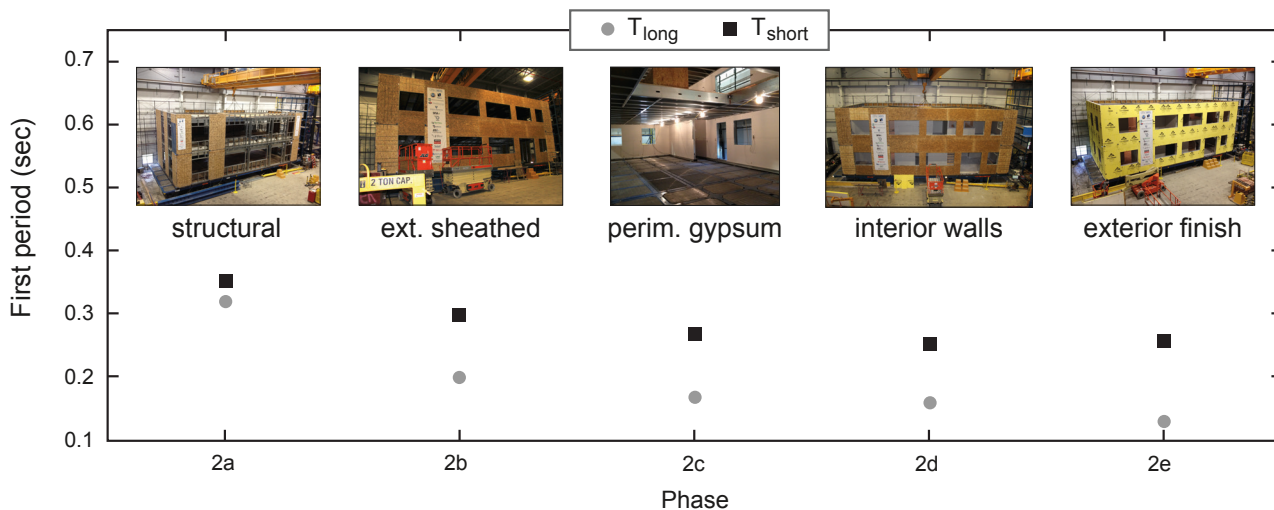


(a) CFS-NEES Phase 1 Building



(b) CFS-NEES Phase 2 Building

**Figure 6-5.** CFS-NEES shake table building testing.



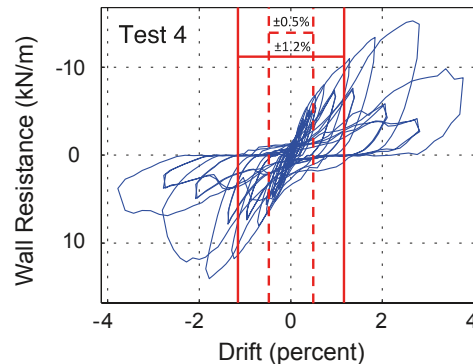
**Figure 6-6.** Measured shift in building period as a function of construction phase (upper squares in plot are short direction and lower dots are long direction).

The CFS-NEES effort also measured damping. Damping for the structural-only building (Phase 1/Phase 2a) in the undamaged state was 4 percent, providing a lower bound value for damping in CFS-framed structures. Damping for the completed building (Phase 2e) is between 8 and 10 percent. Damage, even modest damage, greatly increases the measured damping with values as high as 19 percent recorded (Peterman 2014, Peterman et al. 2016).

### 6.2.2 Overall Building Response

The CFS-NEES building was subjected to two three-axis ground motions: Canoga Park and Rinaldi. Both motions were recorded in the 1994 Northridge, California, Earthquake. At 100 percent, Canoga Park is consistent with a far-field excitation at the Design Basis Earthquake (DBE) excitation level in ASCE. At 100 percent, Rinaldi is consistent with a near-field excitation at the Maximum Considered Earthquake (MCE) level defined in ASCE 7.

The peak recorded story drift across all testing was 1.2 percent, recorded on the Phase 1 (structural only) building at an excitation of 100 percent Canoga Park. The Phase 2e (complete building) at this same excitation had a maximum drift of only 0.5 percent. The Phase 2e (complete building) at an excitation of 100 percent Rinaldi had a maximum recorded drift of 0.7 percent. Provided in **Figure 6-7** are testing results conducted on an OSB CFS-framed shear wall detailed the same as the CFS-NEES building (Liu and Schafer 2012). Highlighted in **Figure 6-7** are a 0.5 percent and 1.2 percent drift demands. The response of the shear wall is modestly nonlinear in these ranges, but significant strength and deformation capacity still exist.



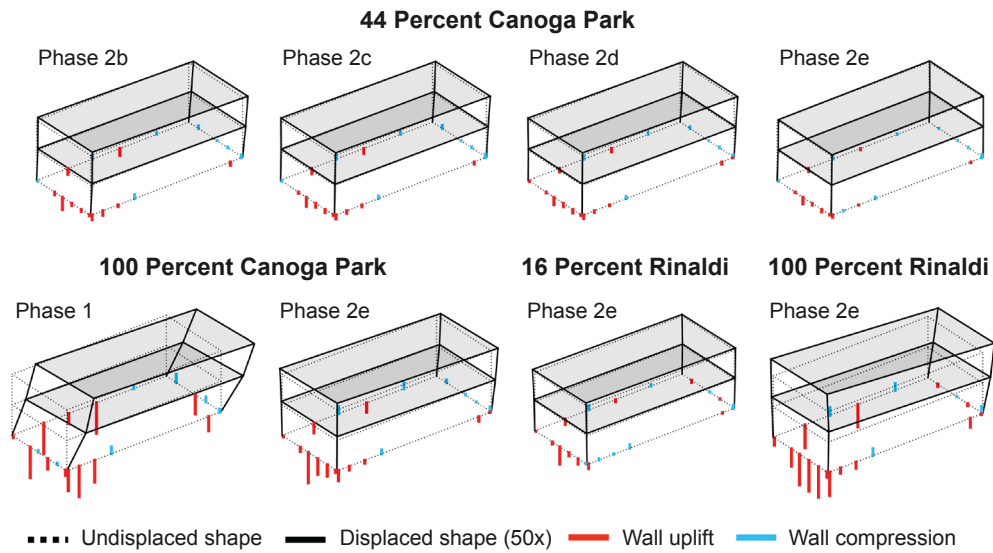
**Figure 6-7.** Response of OSB-sheathed CFS-Framed shear wall test [Liu et al. 2012] (detailed the same as CFS-NEES building) with drifts experienced in CFS-NEES testing highlighted.

The predicted drift at the DBE-level (100 percent Canoga Park), using AISI S213-07/S1-09 to determine the WSP shear wall stiffness and a  $C_d$  of 4 based on ASCE 7 is 1.8 percent (Madsen et al. 2011). The building, even the Phase 1 building that has sheathing only on the shear walls and diaphragm but otherwise has bare steel members is stiffer than predicted.

### 6.2.3 Anchorage Response

The CFS-NEES testing included load cells in the anchor bolts of every hold-down attached to the chord studs of the shear walls. This provides a means to examine the forces in the chord studs. The building was designed and detailed as a series of Type I shear walls (see **Figure 4-3**). The building response is provided at peak deflection in **Figure 6-8**. Although overall the response is complex, at least two major conclusions can be drawn: (1) walls





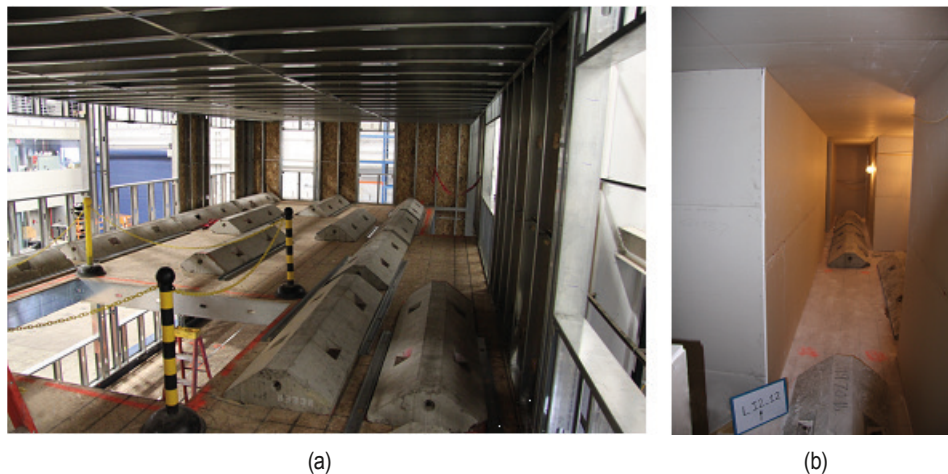
**Figure 6-8.** Measured displaced shape and anchorage forces at peak drift in seismic testing of the CFS-NEES building across excitations and construction phases.

perpendicular to the dominant direction of motion are active, even if the common assumption would be that they are not, and (2) shear walls couple in ways consistent with Type II shear wall behavior, even if not detailed or assumed to perform in this manner.

#### 6.2.4 Diaphragm Response

The CFS-NEES building employs CFS framing with OSB sheathing for its diaphragms (see **Figure 6-9**). ASCE prescriptively defines that OSB on CFS framing is a flexible diaphragm. ASCE 7-10 also provides a calculation procedure that indicates when the maximum

diaphragm deflection is greater than 2 times the building deflection, the diaphragm shall be considered flexible. Instrumentation in the short direction of the building allowed for a detailed calculation of the diaphragm deflections during testing, and the measured ratio was only 0.28. Thus, the measured performance is essentially aligned with a rigid diaphragm assumption. To address this inconsistency, the method noted in Section 5, assuming both a flexible and rigid diaphragm and taking the worst case demands, was followed in the design of the CFS-NEES building.



**Figure 6-9.** View inside of the CFS-NEES building showing supplemental mass on the floor and details of the floor and roof diaphragm (a) Phase 1/Phase 2a, (b) Phase 2e.

### 6.3 Components

In addition to testing on shear walls and complete buildings, testing has also been conducted on many of the components that are employed in cold-formed steel framing. These tests are used in design today or form the basis for future methods, as discussed in Section 11 of this Guide. Briefly discussed here are three key components: hold-downs, fasteners, and CFS members.

Hold-downs or inter-story ties are a critical element in the design of CFS SFRSs. Both the strength and the stiffness of these components must be considered in design. AISI S400-15 does not provide an explicit method for this determination but instead refers to the AISI S913-13, *Test Standard for Hold-Downs Attached to Cold-Formed Steel Structural Framing* (AISI 2013b) test standard for establishing strength and stiffness of these components. Manufacturers provide components that have been tested to this standard. Components specified and employed in the CFS-NEES building were based on test data made publicly available by the manufacturer.

#### AISI Test Standards

All AISI Test Standards, including AISI S913-13, are available for download at <https://cfsei.memberclicks.net/publications>

Many cold-formed steel lateral systems critically rely on the performance of fasteners in shear. For example, the wood-to-steel fasteners used in WSP shear walls are the critical energy dissipating mechanism and the most important contributor to the stiffness and strength of those shear walls. As discussed further in Section 11 of this Guide, developing mechanics-based predictions of many shear walls is possible if the hysteretic performance of the local stud-fastener-sheathing connection in shear is known (Buonopane et al. 2015). Limited existing data provide hysteretic performance of wood-to-steel fasteners in shear (Fiorino et al. 2007, Peterman et al. 2014). The hysteresis for shear of a single fastener connected to a small segment of wood and steel is nearly identical in shape to the hysteresis of a complete wall. AISI is sponsoring a testing program at Virginia Polytechnic Institute, which will provide a more complete set of data on wood-to-steel fastener performance in shear.

The performance of steel-to-steel fasteners in shear for steel sheet and strap-braced shear walls and other CFS systems can be equally influential in understanding the

response. AISI S100-12 provides guidance on steel-to-steel fastener strength, and AISI S310-13 provides additional information on expected stiffness for many steel-to-steel connections. A recently completed series of tests provides steel-to-steel stiffness and strength, including prediction methods for steel sheet thickness from 0.033 inches to 0.097 inches (0.84 mm to 2.46 mm) and fasteners from No. 8 to No. 12 (Moen et al. 2016). This data can be used when analyzing connection stiffness, strength, and ductility in situations not directly envisioned by AISI specifications.

Unlike hot-rolled steel systems, which directly rely on the cyclic performance of structural members, CFS systems do not typically consider the cyclic performance of their members. However, recent experiments provide detailed predictions for the cyclic performance of cold-formed steel members in compression (Padilla-Llano et al. 2014) and bending (Padilla-Llano et al. 2016), with the members undergoing local, distortional, or global buckling (see Section 2) failures. In addition, based on experiments, a method has been developed for predicting the backbone moment-rotation response of cold-formed steel beams across all ranges of cross-section slenderness (Ayhan and Schafer 2016). This testing and the developed prediction methods potentially provide a means to build up cold-formed steel response directly from the members, an exciting future prospect for cold-formed steel seismic systems.

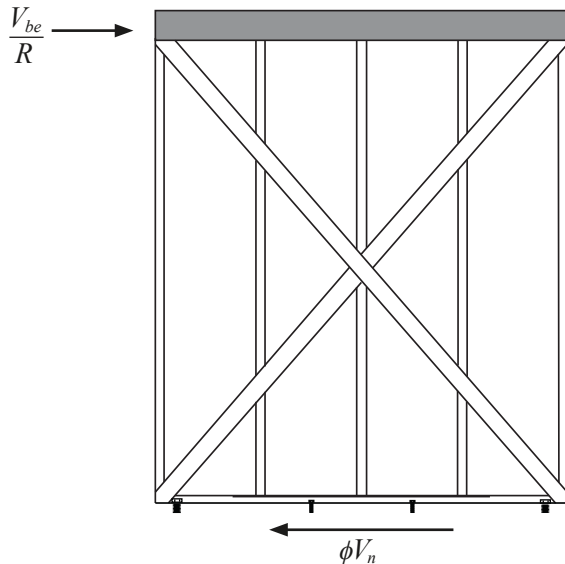


## 7. Advanced CFS SFRS Topics

### 7.1 System Effects, $R$ and $\Omega_o$

The  $R$  and  $\Omega_o$  factors play important roles in the equivalent lateral force (ELF) procedures of ASCE 7, but their implications for seismic response are not widely understood. Discussion in Uang (1991) and SEAOC (1999, 2008) provide important insights on the objective of these factors in seismic design. Additional discussion is provided here specific to repetitive framed structures and the AISI S400-15 standard.

The design basis for the application of  $R$  is straightforward, as summarized in **Figure 7-1**. The elastic base shear ( $V_{be}$ ) is reduced by  $R$ , and the design lateral strength ( $\phi V_n$ ) of the SFRS resisting the demand must be greater than or equal to this demand.



**Figure 7-1.** Design system: demand base shear ( $V_{be}/R$ ) equal to design capacity ( $\phi V_n$ ).

The reduction in the elastic base shear assumed to be delivered to the SFRS is due to two primary effects: (1) inelastic reduction in demand driven from ductility of the system and (2) overstrength (the expected or probable strength of the system is greater than the nominal strength of the SFRS). The reduction in the base shear because of ductility is the factor  $R/\Omega_o$ . In fact, other nations, such as Canada, and earlier versions of seismic standards in the United States (SEAOC 1999) explicitly express  $R$  in terms of factors for ductility ( $R_d$ ) and overstrength ( $R_o$ ) to make this fact clear:

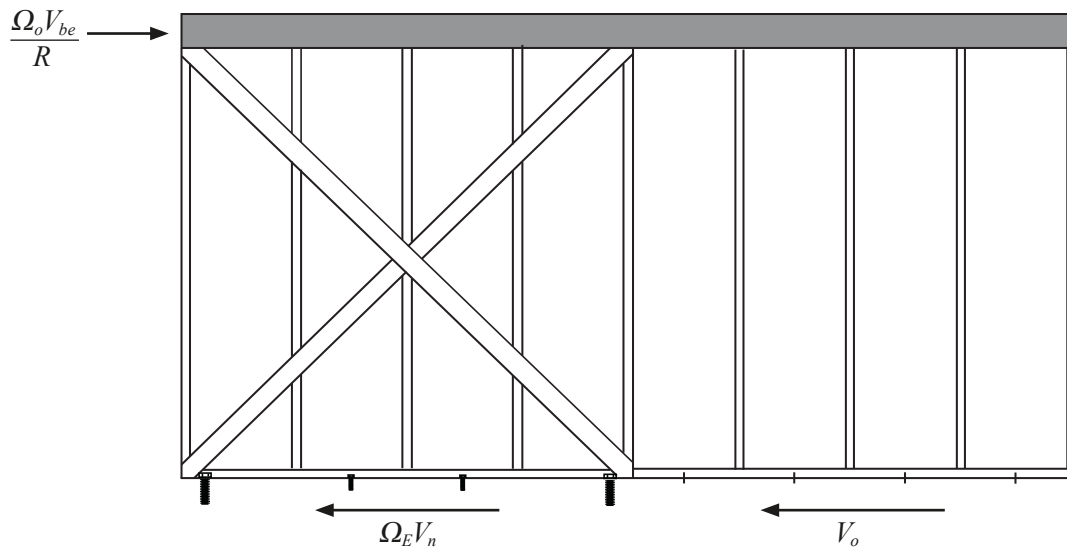
$$\begin{aligned}\phi V_n &= \frac{V_{be}}{R} \text{ (United States)} \\ &= \frac{V_{be}}{R_d R_o} \text{ (Canada)} \\ &= \frac{V_{be}}{R_d \Omega_o} \\ R_d &= \frac{R}{\Omega_o}\end{aligned}$$

Because AISI S400-15 includes the Canadian provisions alongside the U.S. provisions, it is sometimes prudent to read the Canadian provisions and commentary because the explicit treatment of  $R_d$  and  $R_o$  provides clarity in a number of design situations that may be somewhat opaque in the U.S. methodology. In the expressions above,  $R_o$  and  $\Omega_o$  are assumed identical, but because of a desire to provide lowerbound ( $R_o$ ) or upperbound response ( $\Omega_o$ ) for the same overstrength phenomena, they are typically assumed to be about 10 percent different (SEAOC 1999).

Overstrength in the system is represented by the factor,  $\Omega_o$ . Overstrength is defined by Uang (1991):

Structural overstrength results from internal force redistribution (redundancy), higher material strength than those specified in the design, strain hardening, deflection constraints on system performance, member oversize, minimum requirements according to NEHRP [or codes and standards in general] regarding proportioning and detailing, multiple loading combinations, effect of nonstructural elements, strain rate effect, and so on.

AISI S400-15 separates overstrength directly attributed to the SFRS from that of the system as a whole, using the expected strength factor,  $\Omega_E$ , for the SFRS overstrength. The expected strength of the SFRS may exceed the nominal strength because of the final installed condition of the SFRS. For example, consider a shear wall with WSP panels in the installed condition has gypsum board and other finish materials providing additional fasteners to and through the WSP and thus creating additional strength.



**Figure 7-2.** Code estimate of actual system response, actual system: demand base shear ( $\Omega_o V_{be}/R$ ) equal to expected capacity of designated LFRS ( $\Omega_E V_n$ ) plus capacity of all other parts of the system that resist shear but are not explicitly accounted for ( $V_o$ ).

The best estimate of the demand on the actual system is not  $V_{be}/R$  but rather  $\Omega_o V_{be}/R$ . This base shear demand is resisted by the entire system, as depicted in **Figure 7-2**. The entire system includes the expected or probable strength of the SFRS (defined in AISI S400-15 as  $\Omega_E V_n$ ) and any other part of the system that contributes to lateral load resistance (i.e.,  $V_o$  contributed by gravity walls, nonstructural walls, or other effects as described in Uang (1991)).

AISI S400-15 §E1.3.3 and §E2.3.3 sets  $\Omega_E = \Omega_o$  for shear walls where specific data on SFRS overstrength are unavailable. For cases where SFRS overstrength is tightly defined, such as strap-braced walls, available data, such as the bias between the nominal yield stress and expected yield stress of a strap ( $R_y$ ), are employed to define  $\Omega_E$  (i.e.  $\Omega_E = R_y$ ). Force balance for the actual system (**Figure 7-2**) demonstrates how the AISI S400-15 selection of  $\Omega_E$  and the ASCE 7 assumption of  $\Omega_o$  provide a means to assess how much of the base shear is actually assigned to this implicit “other.” The force balance equation is

$$\frac{\Omega_o V_{be}}{R} = \Omega_E V_n + V_o$$

When the shear wall is sized to exactly match the demand (see **Figure 7-1**), and if this relationship is substituted for  $V_n$ , it results in:

$$\frac{\Omega_o V_{be}}{R} = \Omega_E \frac{1}{\phi} \frac{V_{be}}{R} + V_o$$

This equation can be solved for  $V_o$  in terms of the systems and SFRS Overstrength factors and the resistance factor of the shear wall:

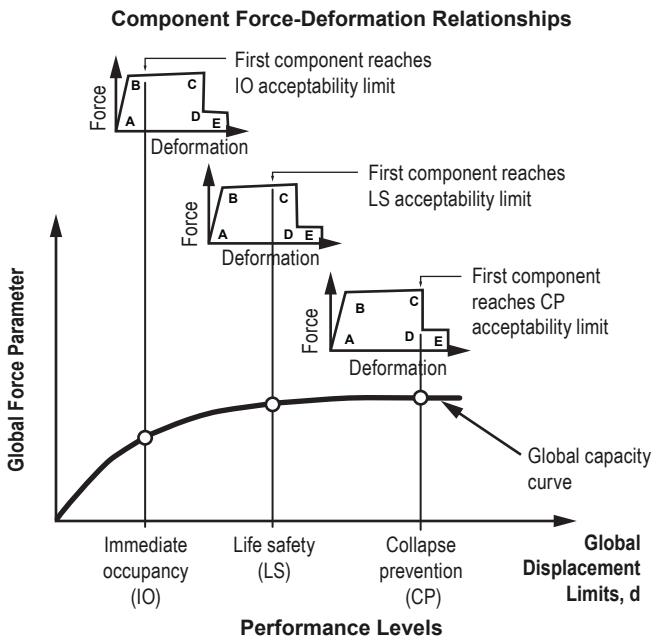
$$V_o = \left( \Omega_o - \frac{\Omega_E}{\phi} \right) \frac{V_{be}}{R}$$

This formula has two consequences: (1) an upper bound for the AISI S400-15 values of  $\Omega_E$  is  $\phi \Omega_o$  is reasonable because this would imply all overstrength is in the SFRS itself and (2)  $V_o$  in many common systems may not be zero. Experience in the CFS-NEES full-building testing described in Section 6 shows that  $V_o$  is significantly greater than zero (Schafer et al. 2016).

## 7.2 Performance-Based Design Considerations

Seismic design performed according to ASCE 7 and AISI S400-15 has as its implicit objective collapse prevention of the structure against anticipated seismic events. This objective is necessary but not always sufficient. It has been found that the cost of damage after seismic events can greatly exceed societal expectations. New approaches have emerged to address this situation. Seismic performance-based design defines several levels of performance from fully operational to collapse prevention and attempts to ensure that the building structure meets the intended performance objective.

In practice this typically means limiting the drift of the structure. As **Figure 7-3** indicates, increasing levels of drift are generally associated with increased damage. Furthermore, **Figure 7-3** provides one way to conceptualize how the global drift demands are experienced by the local components. Thus, checking the components in a nonlinear static pushover is one means of exploring the component response to global drifts. This method, which was first formally envisioned in FEMA 273, *NEHRP Guidelines for the Seismic Rehabilitation of Buildings* (FEMA 1997), has been implemented in ASCE 41. The complexity of this method can far exceed that of current design, but the design method of ASCE 41 provides an avenue forward to better meet increased societal expectations for seismic design.



**Figure 7-3.** Response across levels and basis for ASCE 41.

While ASCE 7 has as its objective collapse prevention, ASCE 41 at the collapse prevention level does not yield the same design solution as ASCE 7. Even for an ELF-based design, ASCE 7 and ASCE 41 use different methods—even for assigning the basic acceleration demands at the site locations—and they result in different solutions. The widespread use of the approach of ASCE 7 for collapse prevention generally has made this solution more acceptable in practice, but whether it is more or less correct than ASCE 41 is unknown.

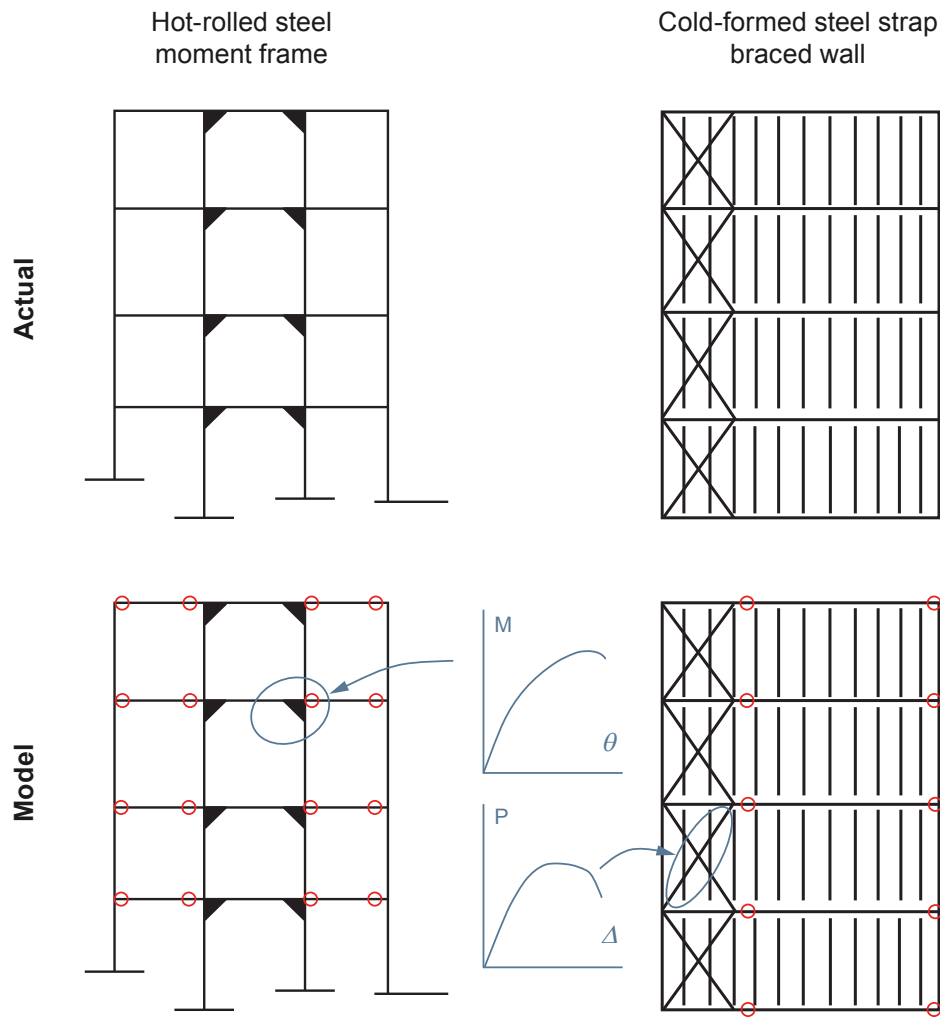
### 7.3 Nonlinear Modeling

To date seismic design of CFS structures is dominated by ELF methods and simplified hand calculations and

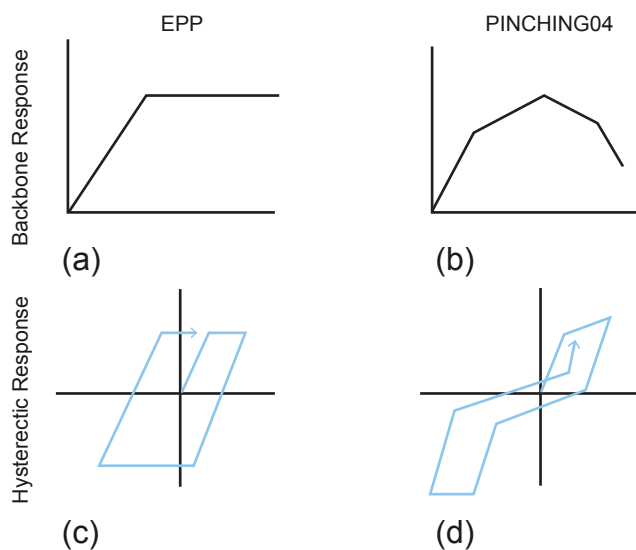
spreadsheets. The seismic design of CFS structures may be contrasted with seismic design of mid- to high-rise buildings with framing composed of hot-rolled steel members, where numerous software applications exist that can provide a variety of analyses for generating the demands. Elastic response history or response spectra analysis, nonlinear static pushover analysis, and inelastic response history analyses are all often performed and are supported by software.

The nonlinear static pushover response of the buildings is shown in **Figure 7-4**. As long as the backbone curve for all deformation-critical elements is properly defined, an analysis has the potential to generate such a curve. For a hot-rolled steel structure, for example a moment frame, defining the backbone curve of the moment frame implies adequately characterizing the moment-rotation response of the connection and generating the building response based on this component curve. For a cold-formed steel SFRS, a wall element, such as a WSP shear wall or a strap-braced wall, typically has been tested, and nonlinear  $V-\Delta_H$  information is known. This can be converted into an equivalent  $P-\Delta$  relationship for a diagonal such that a braced frame generates the same  $V-\Delta_H$  response. It is typically necessary to have tests on the entire subsystem (e.g., a strap-braced wall) because deformations develop throughout the subsystem, not just at the strap.

The selected analysis approach has a critically important impact on the appropriateness of any choice made in modeling. For example, nonlinear static pushover analyses are only impacted by the backbone curve of the response. However, a nonlinear response history analysis, which is the model producing results closest to actual seismic response, requires a complete hysteretic characterization. A common, simple, nonlinear model for steel is the elastic perfectly plastic (EPP) model. EPP models not only define the backbone, **Figure 7-5(a)**, they also define response under cyclic load, **Figure 7-5(c)**. The EPP model assumes no “pinching” occurs and as a result dissipates significant energy during unloading and reloading. Many CFS lateral systems, such as WSP shear walls, steel sheet shear walls, and strap-braced walls, exhibit significant pinching in their response, as shown in **Figure 6-3**. The Pinching04 model (Lowe and Altoontash 2003), which is implemented in OpenSees (McKenna et al. 2000), is an example of a one-dimensional material model that is capable of capturing pinching and has been used extensively in research (see **Figure 7-5(d)**).

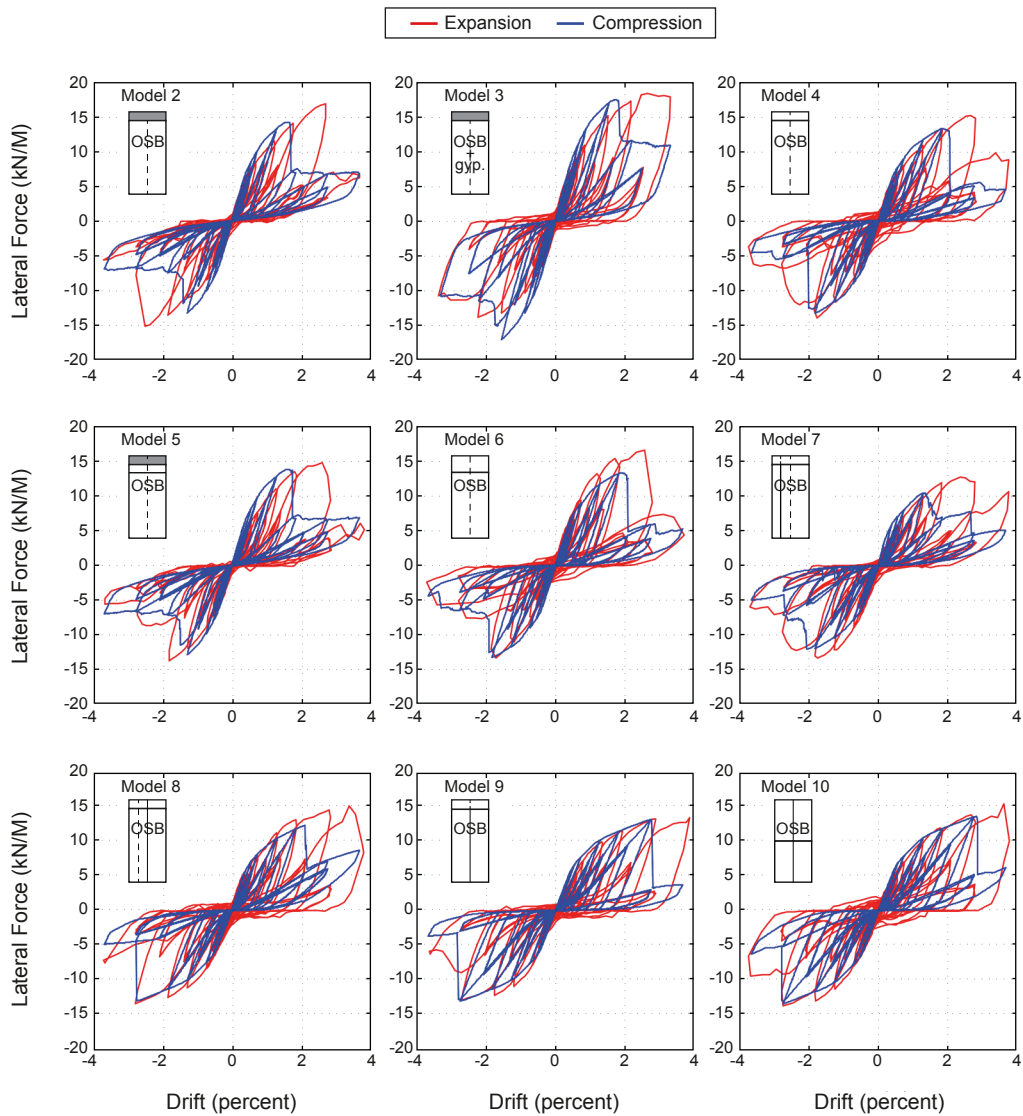
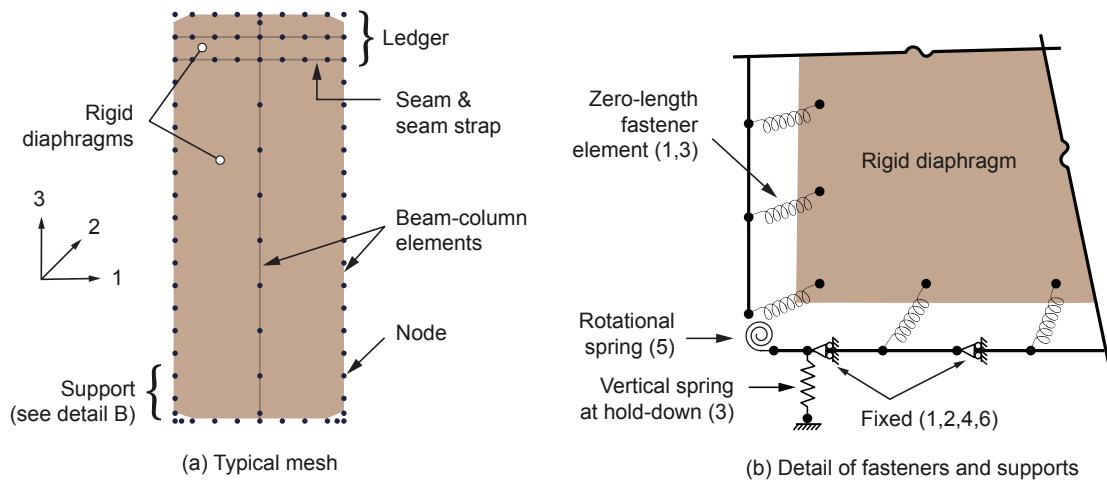


**Figure 7-4.** Comparison of model idealizations for a hot-rolled steel moment frame and a CFS braced frame.



**Figure 7-5.** Comparison of typical nonlinear response curves.

A key challenge in nonlinear modeling of CFS structures can be a lack of data on a subsystem that is to be included in the model. This is particularly pronounced for including the impact of nonstructural systems, such as partitions, and on gravity walls or other subsystems not specifically detailed for lateral load on the response. The CFS-NEES effort revealed that subsystem models built up from fastener response were often useful. First, a model of the exact subsystem is created; second, this model is reduced to its shear deformation response, and third, a simplified one-dimensional model of that response is introduced into the building. A subsystem model used in this manner is depicted in **Figure 7-6**. The CFS framing is included in the model so that its flexibilities are incorporated and so that the framing does not need to be modeled in a subsequent building model. In addition, hold-downs or any other attachments



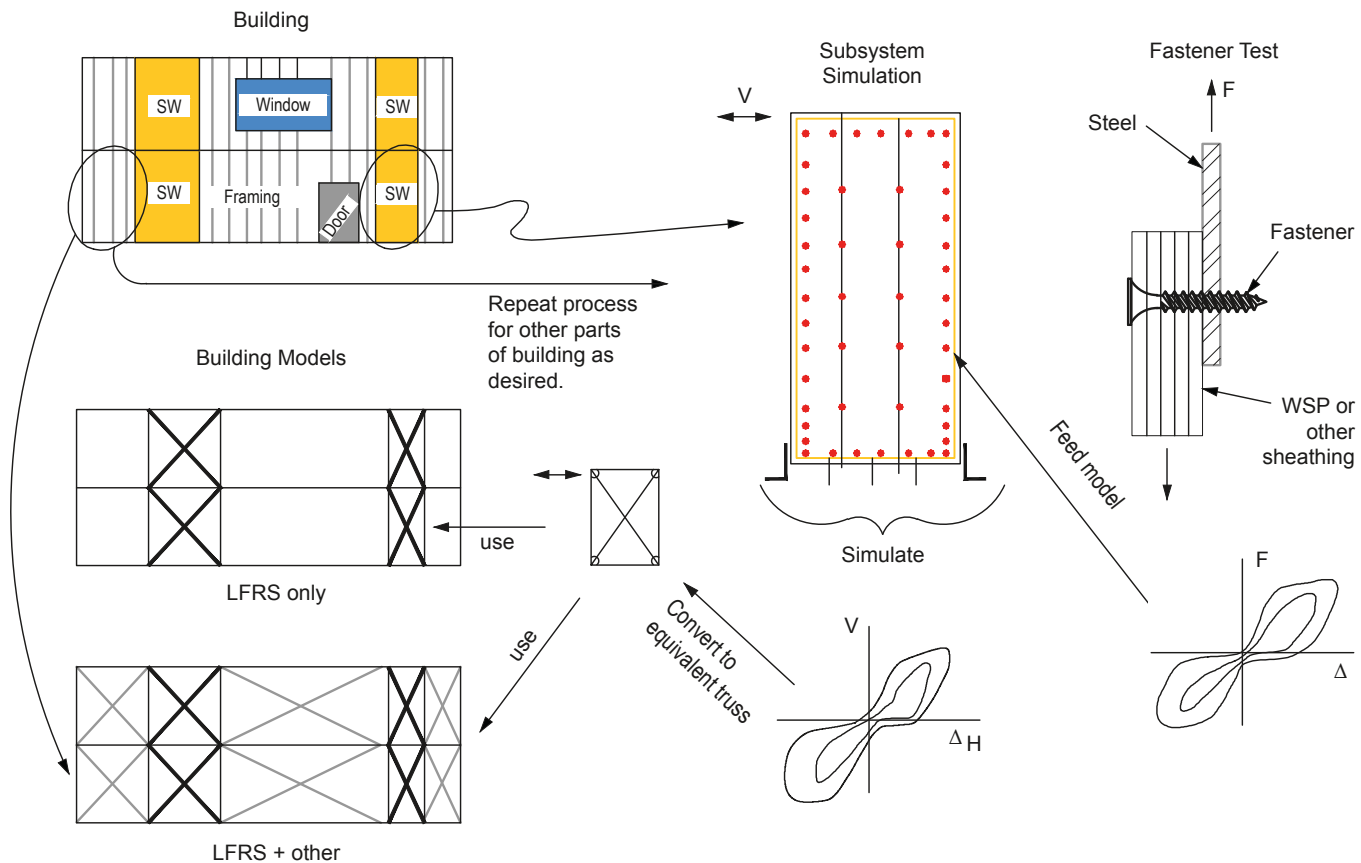
**Figure 7-6.** Fastener-based model of a sheathed CFS wall. Response of the wall is generated from the response of the fasteners. Fastener response is found from isolated testing. Comparison with Liu and Schafer (2012) tests provided.



that are not explicitly included in the building model should be included in the subsystem model. The key nonlinearity is the behavior at the fasteners. The fastener behavior is experimentally characterized in a simple shear test (see Peterman et al. 2014 for an example). The model may be exercised to determine its global shear deformation response (Buonopane et al. 2015), which is characterized by a global Pinching04 model or similar model and introduced into the building model (Leng 2015).

a CFS building is simplified into nonlinear truss panels. Each panel has a fully characterized hysteretic stiffness based on subsystem simulations. These simulations are mostly driven by experimentally determined fastener response. This method was applied in the CFS-NEES project with good success (Leng 2015) and provides for realistic, yet computationally efficient nonlinear modeling of CFS structures. For multi-story structures, the modeling must include the floor-to-floor ties or another multi-story tie system in the model in addition to the individual panel models.

A nonlinear modeling approach appropriate for CFS buildings is shown in **Figure 7-7**. The lateral resistance of



**Figure 7-7.** An example of a nonlinear modeling paradigm for CFS buildings that builds up the response from subsystem simulations that rely largely on fastener testing and ultimately creates whole building models either of the LFRS alone or of the LFRS and the other systems, depending on the desire of the analyst.

## 8. ASCE 41 Applications

ASCE 41, *Seismic Evaluation and Retrofit of Existing Buildings* (ASCE 2014) is commonly the standard specified for seismic engineering of existing buildings and is occasionally specified as the governing standard for seismic design of new buildings. The performance-based methods presented in ASCE 41 differ significantly from the methods common to the IBC and ASCE 7. The method has not yet been as widely used as ASCE 7, but engineers will need to be increasingly aware of this alternative design philosophy.

The ELF procedure in ASCE 41 focuses on demand-to-capacity ratios for the elements in the building, but rather than allowing a single value (akin to  $R$ ) for this ratio provides detailed values for framing systems as a function of the desired performance. In addition, ASCE 41 provides a means to analyze the nonlinear performance of the building through full backbone (e.g.,  $V-\Delta$ ,  $M-\theta$ ) curves for critical components that undergo energy dissipating deformations in a seismic event. The method, which is aligned with the ASCE 41 ELF procedure, provides one means to understand how modeling may be used within the context of approved code provisions to provide a more detailed depiction of response.

ASCE 41 provides very little information relative to CFS-framed structures or CFS SFRSs. In fact, there are no common CFS archetype structures listed as “Common Building Types” in ASCE 41. The simpler Tier 1 and Tier 2 evaluation and retrofit procedures presented in ASCE 41 cannot be applied to existing CFS building types. As such, Tier 3 procedures are required, which rely on significantly better knowledge of as-built conditions as well as on more rigorous analysis of elements expected to resist seismic forces. In addition, various design coefficients and factors along with strength and stiffness parameters required to estimate seismic forces, displacements, and strength of CFS systems are not included. Thus, ASCE 41 is very difficult to implement for common CFS buildings.

### Expected Changes in ASCE 41-17 to Provide a Comprehensive CFS Design Methodology

A concerted effort is underway to resolve these CFS issues in ASCE 41-17. These changes should provide a comprehensive methodology to apply ASCE 41 to CFS-framed buildings and bring ASCE 41 into alignment with AISI S400-15. Common building types will be included, allowing Tier 1 and Tier 2 procedures to be used, and data will be added to assess structural performance levels and associated levels of expected damage.

Design coefficients and factors required to evaluate CFS systems and design retrofits are also being developed for inclusion in ASCE 41-17. These values will be based on existing research databases for shear walls, strap-braced walls, and the full-scale shake table testing completed under the CFS-NEES effort.

The changes required to implement comprehensive provisions for CFS will be found throughout ASCE 41-17, but the material-specific provisions will be in Chapter 9 alongside the structural steel provisions.

## 9. Additional Considerations

When CFS framing is used as the main structural system, the construction documents should be specific as to all connections, details, and materials. This documentation is particularly important for the SFRS because the detailing and materials can have significant impact of the performance on the system. Some CFS members and connections include elements with limit states including flexural and flexural-torsional buckling of members as well as potentially low ductility connections. Design of the LFRS should consider all limit states of the system and ensure that the ultimate behavior of the system is predictable and ductile.

Light frame CFS systems are structurally efficient. A significant portion of the costs associated with CFS framing is the labor used to assemble the system. The detailing of the systems is critical to producing a design that minimizes the cost of materials. The shear wall boundary elements are one of the major components that can affect the overall cost of the LFRS. The elements themselves are typically constructed of multiple CFS members combined to form an element of sufficient strength. Where combined CFS sections are not adequate, structural steel elements are frequently added to complete the system (see Section 4 for design of boundary elements). These components are typically constructed on a floor-by-floor basis with some connection element through the floor system. Transmitting the large compressive forces through the floor in a platform-framed system requires special detailing and as a practical matter may preclude this type of system for multi-level structures with numerous shear walls.

Current design practice for multi-level timber framed construction frequently employs a continuous rod tie-down system for shear wall boundary elements. Although such systems frequently are used in CFS framed walls, their use is not as compelling. Shrinkage of the floor framing is a concern with wood floor and roof framing but not with CFS framing, and connections in steel to transmit forces from floor to floor are significantly more compact than timber framing. Seating of studs in tracks can cause  $\frac{1}{16}$  to  $\frac{1}{8}$  inch (1.6 to 3.2 mm) compression in the wall assemblies leading to undesirable slack in floor-to-floor connections without proper detailing. These advantages of CFS framing over comparable wood structures may allow for simpler floor-to-floor load transfers at boundary elements.

For CFS systems, 2015 IBC §1705.11.3 requires “periodic special inspection during welding operations of elements of the seismic force-resisting system. Periodic special inspection is required for screw attachment, bolting, anchoring and other fastening of components within the seismic force-resisting system, including shear walls, braces, diaphragms, collectors (drag struts) and hold-downs.” There are some exceptions to this requirement for low-stress structures. In addition to the requirements of the 2015 IBC, the engineer of record should consider the level of quality assurance and quality control that is appropriate for a given circumstance. Influencing factors may include use or occupancy of the completed structure, level of experience of the construction crew in this type of construction, complexity of the design and confidence in the knowledge of special inspectors, and the authority having jurisdiction.

CFS lateral systems may not be well known by the builder or the inspectors assigned to review them. If this is the case, the structural engineer of record should consider preconstruction meetings and periodic structural observations to ensure that designs are being properly constructed. Waiting to complete the observations until the structure is complete is generally not desirable because faulty construction could be repeated throughout the structure by the time it is discovered. Budgeting for structural observations throughout the construction process to catch any potential issues early on is more economical than waiting to observe the completed structure. During the course of construction any variations from the approved design should be reviewed and resolved by the engineer of record.

CFSEI Technical Note G500-11 *Guidelines for Inspecting Cold-Formed Steel Structural Framing in Low Rise Buildings* (CFSEI 2011) is a good guide for the inspections. *Steel Framing Inspection Guide* published by the Steel Framing Alliance, Steel Stud Manufacturers Association, and American Iron and Steel Institute (SFA 2008) is also a useful tool, but is oriented more toward smaller residential structures. Below is a simplified list of items that should be covered during an inspection.

### 9.1 Materials

Steel verification should consist of verifying the size, type, mechanical properties, and spacing of members. Steel grades should be checked to comply with designs.

Mill certifications for steel can be checked to ensure steel grades. However, the mill certifications are typically done when the steel is in the coil stage. The coils are then slit and rolled into the various sections, such as studs, tracks, and clips by the manufacturer. To a large extent, one must rely upon the manufacturer to ensure that the coils are tracked to the appropriate members. Manufacturers are required to label studs and tracks with size and steel grade. Members should have legible stickers, stamps, stencils, or embossing spaced a maximum of 8 feet (2.44 m) on center identifying the material thickness, yield strength, coating, product designation, and manufacturer. Member condition should be checked. Tolerances can be found in ASTM C955-15, *Standard Specification for Load-Bearing (Transverse and Axial) Steel Studs, Runners (Tracks), and Bracing or Bridging for Screw Application of Gypsum Panel Products and Metal Plaster Bases* (ASTM 2015) and AISI S240-15.

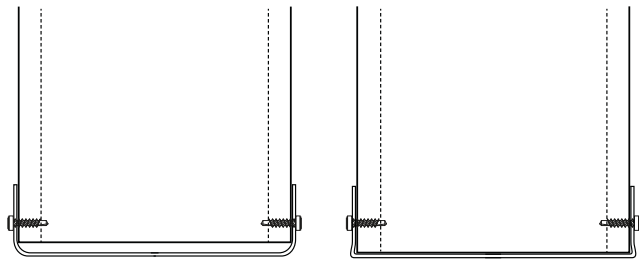
## 9.2 Connections

Because connections are critical for the SFRS, proper construction must be ensured. Screw connections should be checked to ensure that screws installed meet the project specifications and design assumptions. Type, size, number, and installation of screws should be checked. Installation review of screws should include proper penetration through steel, seating, popped heads, stripping, spacing, and edge distances. AISI S240-15 provides guidance for the acceptable percentage of stripped screws. At the discretion of the engineer, that guidance may not be applicable to critical connections.

Welding inspections should be done per American Welding Society (AWS) D1.1 *Structural Welding Code—Steel* (AWS 2015) for structural steel to structural steel or AWS D1.3 *Structural Welding Code—Sheet Steel* (AWS 2008) for CFS to CFS or CFS to structural steel. Bolts, if used, should be installed in holes no greater than the diameter of the bolt plus  $\frac{1}{16}$  inch (1.6 mm) for  $\frac{1}{2}$ -inch (12.7 mm) diameter or smaller bolts and diameter plus  $\frac{1}{8}$  inch (3.2 mm) for larger than  $\frac{1}{2}$ -inch (12.7 mm) bolts. Some nuts may have to be removed to check hole sizes. Foundation sill plate anchorages are often problematic because of tolerance variation between concrete construction and CFS framing construction. If the holes are oversized at this critical location, weld washers or other means may need to be installed.

## 9.3 Walls

Seating of the studs into the tracks and uneven or out-of-level foundations can cause gaps below the tracks or gaps between the studs and tracks in bearing and/or shear walls. Gaps of  $\frac{1}{16}$  inch (1.6 mm)—AISI S240-15 C3.4.3 allows  $\frac{1}{8}$  inch (3.2 mm)—or less are desired for 0.054 inch (1.4 mm) or thicker stud-and-track. Greater gaps can cause screw failures during seating or loading of the stud to track connection. This can be problematic with thicker steel members because the radius of the bend on the inside of the tracks can make seating of studs into tracks difficult. For this reason, tracks in bearing walls and shear walls are typically “over-rolled” or produced wider than the studs to allow the stud to seat properly. Upon installation of the screw from the track to the stud, the leg of the track will bend inward to seat against the stud (see **Figure 9-1**).



**Figure 9-1.** Over roll of track for proper stud seating.

Wall stud bracing and bridging should be checked to conform to contract documents. Shear wall boundary elements may have special bracing requirements that should be checked, including after installation of utilities because utility installation is often at odds with the bracing and because modifications to bracing frequently occur. In some circumstances, the wall sheathing may be used to provide wall bracing. The sheathing may not be present at the time of structural observations of the framing. Supplemental observations may be required to confirm proper attachment of sheathing.

## 9.4 Shear Walls and Strap Bracing

Sheathing and strap bracing should be verified to match design requirements. Fastener spacing and installation should be checked at shear walls to comply with required edge distances and penetration of the fastener heads into the sheathing. Over-driven or under-driven fasteners



should be reviewed and corrected as applicable. Refer to AISI S240-15 §C4.1.3, Commentary C4.1.3, and Table D6.9-4 for guidance on this subject.

Of particular concern is the tautness of the diagonal straps after application of dead loads to the structure. Most of the structure dead load is in the finishes that are added to the structure after inspection of the structural systems. **Figure 9-2** shows a CFS load-bearing system prior to the installation of finishes.

Floor and roof diaphragms should be viewed in the same light as shear wall diaphragms because they are an integral part of the LFRS as defined by AISI S400-15.

Quality control for the installation of cold-formed steel deck and deck accessories for floors or roofs is covered in SDI QA/QC—2011 *Standard for Quality Control and Quality Assurance for Installation of Steel Deck* (SDI 2011).



**Figure 9-2.** Structural systems inspected prior to wall finishes and application of majority of dead load.



## 10. Special Bolted Moment Frames (CFS-SBMF)

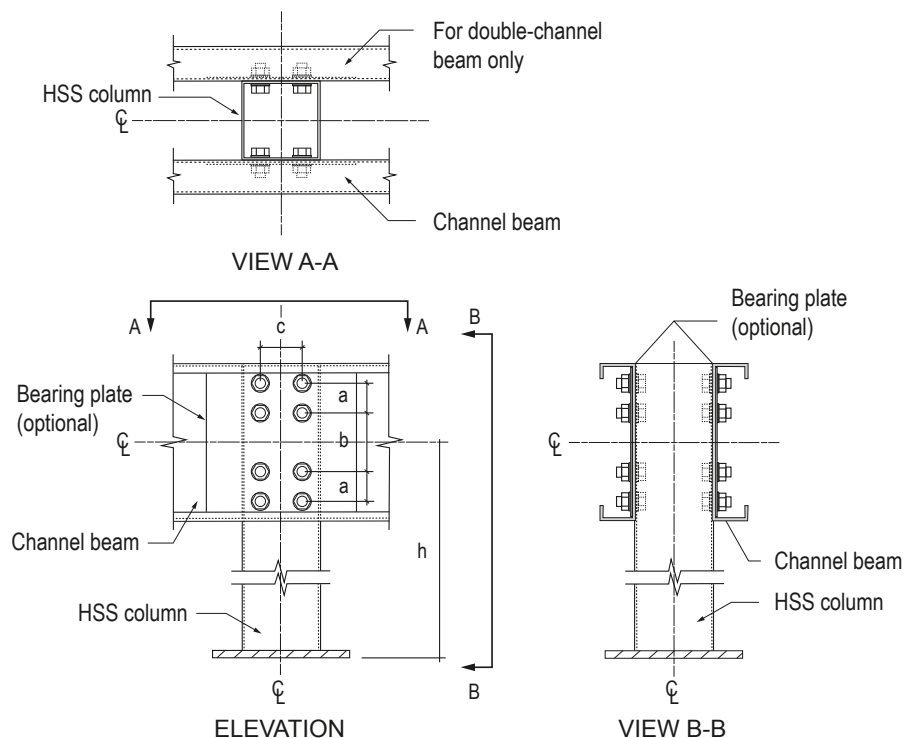
AISI S400-15 Chapter E4 is the design standard for CFS-SBMF systems. This type of one-story framing system features C-section beams connected to hollow structural section columns by bearing-type high-strength bolts and is commonly used in industrial platform construction. Example detailing of this system is shown in **Figure 10-1**.

CFS-SBMFs withstand inelastic deformations through friction and bearing at their bolted connections. Beams, columns, and connections shall satisfy the requirements of S400-15 and shall be limited to one-story structures no greater than 35 feet (10.7 m) in height. The CFS-SBMF shall engage all columns supporting the roof or floor above. A single beam size and column with the same bolted moment connection detail shall be used for each frame. Because of these limitations this system is mostly used for industrial single-level mezzanines and cannot be used for multi-level construction. The advantage of this system is that the field construction is fast and does not require welding. These systems lend themselves to uses that are repetitive and regular in column spacing.

The design of CFS-SBMFs require that connections be configured such that a ductile limit state in the connection, such as localized yielding around the

fastener or bearing deformation, controls the available strength. Test results for this system show that specimens had an inter-story drift capacity significantly larger than 0.04 radians. The cyclic behavior was characterized by a linear response, a slip range, and a significant hardening response because of bearing at bolt holes.

The strong column-weak beam design philosophy associated with structural steel moment frames is not appropriate for this system. Rather than relying upon yielding of the frame beam, the CFS-SBMF relies on inelastic action through bolt slip and bearing in the connection as a ductile yielding mechanism. Beams and columns are protected to remain elastic by capacity design principles. Drift calculations should include not only deformations due to member deflections but also deformations in the connections. Connection stiffness can be modeled using empirical data available on tested assemblies or reasonable extrapolations of such data to account for connection geometry. Table 12.2-1 of ASCE 7 includes seismic design parameters for CFS-SBMF systems of  $R = 3.5$ ,  $\Omega_o = 3.0$  and  $C_d = 3.5$ . AISI S400-15 includes specific requirements for quality assurance and quality control procedures.



**Figure 10-1.** CFS-SBMF connections.

# 11. The Future of CFS Seismic Force-Resisting Systems and Design

This Section of the Guide addresses expected future developments in cold-formed steel seismic force-resisting systems and seismic design. Seismic engineering for cold-formed steel framing has evolved rapidly since initial testing conducted on shear walls in the 1990s. Although initial research and code provisions often sought to duplicate solutions found for wood structures, more recently cold-formed steel framing is developing solutions unique to its own strengths and weaknesses. This trend is expected to continue as cold-formed steel framing evolves.

## 11.1 Ongoing Research and Advancements

Research in seismic design of CFS framing is ongoing worldwide, including in higher performance shear walls, system-level design, diaphragms, fundamental component research, and building modeling. This research is highlighted here because it is anticipated to have significant impact on the possibilities available to engineers.

### 11.1.1 Higher-Strength, Higher-Ductility SFRS

The available strength of SFRSs in AISI S400-15 is limited by the range of existing test data. The application of steel sheet shear walls provides one pathway towards increased capacity that is being directly explored. Tests at McGill University by Rogers are being conducted in 2016. Corrugated steel sheet shear walls, where the corrugations are specifically designed for controlled yielding, has been shown in Japan to provide high strength and ductility (Shimizu et al. 2013) and provides another solution with excellent future potential. Japanese research has also shown how to introduce replaceable ductile fuses into CFS shear walls through special purpose hold-downs (Ozaki et al. 2013). In concept, the idea of replaceable ductile fuses has been extended to the wall itself with a demonstrated potential for high strength, high ductility, and repairability (Comini and Schafer 2014). In some cases the limitation for the wall is the boundary members, particularly the chord studs, rather than the sheathing. In addition to using alternative chord stud members (e.g., hot-rolled steel members) or materials (e.g., composite concrete), current research on built-up cold-formed steel members, including those with high strength steel,  $F_y > 100$  ksi (689 MPa) are also aimed at improving this situation.

### 11.1.2 Integrated Systems

CFS seismic design does not have to imply 100 percent application of CFS. A number of integrated solutions show excellent possibilities. For example, consider a CFS-framed shear wall: to achieve higher capacity chord studs, well detailed hot-rolled HSS sections may replace the CFS chord studs. This replacement has already been used with success and shows excellent potential in the right situation. This solution may potentially be investigated as a formal CFS framing SFRS. Concrete composite construction possibilities also exist for CFS-framed shear walls. Investigations of this type have not been common in North America but are popular in research performed in some other countries (e.g., Feng et al. 2010).

In multi-story construction, an efficient system may use reinforced concrete or masonry walls around the elevator or stair cores with all remaining wall and floor framing completed with CFS. The LFRS would be a mixture of an existing CFS SFRS system and the elevator/stair core systems. Such mixed or dual systems are allowed in ASCE 7 today, but efficient performance and connection details are largely uninvestigated. These integrated systems have the potential to improve the economy of this form of construction.

### 11.1.3 Diaphragms

Significant research is underway to better predict the stiffness, strength, reliability, and ductility of CFS-framed diaphragms and integrate that additional understanding into design (e.g., Chatterjee et al. 2014, Nikolaidou et al. 2016). The AISI S400-15 §F2 provisions for diaphragms constructed of CFS with WSP were based on conservative extension of a limited study. Recent testing and analysis suggest significant improvements are possible. In addition, new design methods that explicitly account for diaphragm ductility are working their way into codes (e.g., the alternative diaphragm design methods proposed for ASCE/SEI 7-16 §10.3). Research to characterize CFS diaphragms for use with these methods is needed.

CFS framing offers flexibility with respect to the diaphragm system, and a number of systems have been used in existing construction. Conceptual work to understand the role of the diaphragm and its characteristics in the system-demand reduction factors

(e.g.,  $R$ ) is ongoing and will provide new insights on how to balance the seismic design of the vertical and horizontal lateral force-resisting systems. This work will be integrated into AISI S400 in the future.

#### 11.1.4 Component-Level Testing and Modeling

A common energy dissipating mechanism in CFS SFRS is related to bearing and damage at fastener locations. These may be steel-to-steel, wood-to-steel, or other material-to-steel connections. Details vary across a wide range of steel thickness, fastener and head size, and configuration. A significant amount of experimental work on cyclic testing of these connections has recently been conducted (see e.g., Moen et al. 2016 for the first in this series), and this information will provide a critical building block in making predictions of subsystems, such as shear walls built-up from this response. In addition, this testing is leading to improved test standards, including improved loading protocols for cyclic testing.

Fundamental to the behavior of thin-walled cold-formed steel members are the stiffness reductions that may occur because of local, distortional, and global buckling under load. These reductions must be captured within designs and models if the full system created by cold-formed steel members is to be assessed. Using existing test data, a new method was developed for determining the stiffness reduction and backbone moment-rotation and/or moment-curvature response under local and distortional buckling (Ayhan and Schafer 2012). Recent testing with carefully selected members and boundary conditions for the study of local, distortional, and global cyclic response of cold-formed steel members loaded axially (Padilla-Llano et al. 2014) and flexurally (Padilla-Llano et al. 2016) have also been completed. The results highlight the energy dissipation capabilities and post-buckling strength and stiffness of CFS members. These results can form the basis for development of seismic force-resisting systems that incorporate complete cold-formed steel member response, as opposed to current systems that largely seek to use alternative mechanisms to resist seismic demands independently from the members, such as bearing in wood or steel connections, or yielding of straps.

#### 11.1.5 Building Modeling

For the structural engineer, building modeling for cold-formed steel framing can be a challenge. The individual CFS members have torsional behavior as well as local and distortional buckling behavior that may not be captured adequately in traditional structural engineering

software. The CFS-NEES effort shows the potential of building-level modeling. Increased accuracy in the prediction of building strength and ductility allows the engineer to advance beyond prescriptive code-based provisions that average system behavior (e.g.,  $R$  and  $C_d$  factors) and instead predict the response of an individual building. Because CFS diaphragms are typically semi-rigid, a simplified building model would seem to be useful. Improvements in and availability of modeling tools for CFS seismic engineers may have the greatest impact on future capabilities in the field.

#### Building-Level Modeling of CFS-Framed Buildings

A paper titled “Seismic Response and Engineering of Cold-Formed Steel Framed Buildings” related to building-level modeling is in press and will be published in *Structures*. The paper is authored by B. W. Schafer et al.

## 11.2 Future Code and Standards Provisions

The seismic provisions of ASCE 7 continue to evolve. For cold-formed steel framing, the use of linear elastic ELF methods and the selection of a single system-level  $R$  factor dominates current design. The introduction of an alternative diaphragm design method proposed in ASCE/SEI 7-16, along with a diaphragm  $R$  factor ( $R_s$ ), portends a future with multiple  $R$  factors and increased complexity for equivalent lateral force methods. This is likely to be true for cold-formed steel framing as well. The increasing application of  $\Omega_o$  force levels across ASCE 7, and the reason for doing this—in general to move towards a more capacity-based design philosophy—will lead to a desire to better tune the  $\Omega_o$  levels to actual systems, which again is likely to increase complexity (note the use of  $\Omega_E$  in AISI S400-15). In addition, prescriptive methods for determination of diaphragm flexibility are likely to give way to more calculation-based methods. Although ELF methods are probably here to stay, standards should continue to encourage nonlinear static pushover and linear and nonlinear response history analyses, and reward the engineer who uses these methods with better predictions of the demands and with less restrictions on the use of the results. The days of designing cold-formed steel framing systems without a building model are ending.

AISI S400-15 provides the capacity-based provisions for CFS seismic force-resisting systems. The next edition of this standard will likely increase the scope

of the prescriptive solutions provided, particularly for steel sheet shear walls and related variants. In addition, analysis-based methods for predicting the behavior of WSP shear walls, strap-braced walls, and steel sheet shear walls, should all improve and provide a design-ready form for engineers. The advancement of capacity-based design provisions and the findings from the CFS-NEES work indicate that further refinement of the system-based expected strength ( $\Omega_E$  factors) will need to be revisited and improved in the next version. Finally, methods to address the lateral performance and contribution of the systems that are not designated as part of LFRS will begin to be included in future editions. This reflects the fact that the system overstrength for CFS-framed LFRS solutions can be relatively high. Means to understand and ensure that the designed system is well-aligned with the assumptions in the systems designated by ASCE 7 will provide increased reliability for these methods. In addition, expansion of the information available for diaphragms is expected in future versions of AISI S400.

ASCE 41 also continues to evolve, particularly as it relates to CFS framing. See Section 8 for additional discussion about ASCE 41.

## 12. References

- AISI (1946). *Specification for the design of light gage steel structural members*, American Iron and Steel Institute, Washington, DC.
- AISI (2004). *Standard for cold-formed steel framing—lateral design* AISI/COFS/Lateral-04, American Iron and Steel Institute, Washington, DC.
- AISI (2006). *The strength of stiffened CFS floor joist assemblies with offset loading, 2006 Revision*, (Research Report RP03-6), American Iron and Steel Institute, Washington, DC.
- AISI (2007). *North American standard for cold-formed steel framing—lateral design* (AISI S213-07), American Iron and Steel Institute, Washington, DC.
- AISI (2009). *North American standard for cold-formed steel framing—lateral design, Supplement No. 1*, (AISI S213-07/S1-09), American Iron and Steel Institute, Washington, DC.
- AISI (2012). *North American specification for the design of cold-formed steel structural members* (AISI S100-12), American Iron and Steel Institute, Washington, DC.
- AISI (2013a). *North American standard for the design of profiled steel diaphragm panels* (AISI S310-13), American Iron and Steel Institute, Washington, DC.
- AISI (2013b). *Test standard for hold-downs attached to cold-formed steel structural framing* (AISI S913-13), American Iron and Steel Institute, Washington DC.
- AISI (2015a). *North American standard for cold-formed steel structural framing* (AISI S240-15), American Iron and Steel Institute, Washington, DC.
- AISI (2015b). *North American standard for seismic design of cold-formed steel structural systems*, (AISI S400-15), American Iron and Steel Institute, Washington, DC.
- AISI (2015c). *North American standard for cold-formed steel framing—nonstructural members* (AISI S220-15), American Iron and Steel Institute, Washington, DC.
- AISI (2016a). *North American specification for the design of cold-formed steel structural members* (AISI S100-16), American Iron and Steel Institute, Washington, DC.
- AISI (2016b). *North American standard for the design of profiled steel diaphragm panels* (AISI S310-16), American Iron and Steel Institute, Washington, DC.
- Al-Kharat, M., and Rogers, C. A. (2005). *Testing of light gauge steel strap braced walls*, Project Report No. 1, McGill University, Montreal, Canada.
- Al-Kharat, M., and Rogers, C. A. (2006). *Inelastic performance of screw connected light gauge steel strap braced walls*, Project Report No. 2, McGill University, Montreal, Canada.
- Al-Kharat, M., and Rogers, C. A. (2007). “Inelastic performance of cold-formed steel strap braced walls,” *Journal of Constructional Steel Research*, 63 (4), pp. 460–474.
- Allen, D. (2006). “History of cold-formed steel,” *STRUCTURE Magazine*, November, pp. 28–32.
- ANSI/AWC (2015). *Special design provisions for wind and seismic* (SDPWS-2015), American Wood Council, Leesburg, VA.
- APA (2011). *Performance-rated panels—product guide* (F405M), APA-The Engineered Wood Association, Tacoma, WA.
- ASCE (2010). *Minimum design loads for buildings and other structures* (ASCE/SEI 7-10), American Society of Civil Engineers, Reston, VA.
- ASCE (2014). *Seismic evaluation and retrofit of existing buildings* (ASCE/SEI 41-13), American Society of Civil Engineers, Reston, VA.



- ASCE (2016). *Minimum design loads and associated criteria for buildings and other structures* (ASCE 7-16), American Society of Civil Engineers, Reston, VA.
- ASTM (2006). *Standard practice for static load test for shear resistance of framed walls for buildings* (ASTM E564), ASTM International, West Conshohocken, PA.
- ASTM (2011). *Standard test methods for cyclic (reversed) load test for shear resistance of vertical elements of the lateral force-resisting systems for buildings* (ASTM E2126), ASTM International, West Conshohocken, PA.
- ASTM (2015). *Standard specification for load-bearing (transverse and axial) steel studs, runners (tracks), and bracing or bridging for screw application of gypsum panel products and metal plaster bases* (ASTM C955), ASTM International, West Conshohocken, PA.
- AWS (2008). *Structural welding code—sheet steel*, (AWS D1.3/D1.3M), American Welding Society, Doral, FL.
- AWS (2015). *Structural welding code—steel*, (AWS D1.1/D1.1M), American Welding Society, Doral, FL.
- Ayhan, D., and Schafer, B. W. (2012). Moment-rotation characterization of cold-formed steel beams, Research Report CFS-NEES, RR02, April 2012, accessed 6/21/2016 at [www.ce.jhu.edu/cfsnees](http://www.ce.jhu.edu/cfsnees).
- Ayhan, D., and Schafer, B. W. (2016). “Characterization of in-plane backbone response of cold-formed steel beams.” *Journal of Constructional Steel Research* (In Press).
- Ayhan, D., Madsen, R. L., and Schafer, B. W. (2016). “Progress in the development of ASCE 41 for cold-formed steel.” *Proceedings of the International Specialty Conference on Cold-Formed Steel*, Baltimore, MD, p. 16.
- Balh, N., and Rogers, C. A. (2010). *Development of seismic design provisions for steel sheathed shear walls*, January Project report, McGill University, Montreal, Canada.
- Balh, N., DaBreo, J., Ong-Tone, C., El-Saloussy, K., Yu, C., and Rogers, C. A. (2014). “Design of steel sheathed cold-formed steel framed shear walls.” *Thin-Walled Structures*, 75 (February), pp. 76–86.
- Blais, C. (2006). “Testing and analysis of light gauge steel frame 9 mm OSB wood panel shear walls,” master’s degree thesis, McGill University, Montreal, Canada.
- Boudreault, F. A. (2005). “Seismic analysis of steel frame/wood panel shear walls,” master’s degree thesis, McGill University, Montreal, Canada.
- Branston, A. E. (2004). “Development of a design methodology for steel frame/wood panel shear walls,” master’s degree thesis, McGill University, Montreal, Canada.
- Branston, A., Chen, Y. C., Boudreault, F. A., and Rogers, C. A. (2006). “Testing of light-gauge steel-frame–wood structural panel shear walls.” *Canadian Journal of Civil Engineering*, 33, pp. 561–572, doi: 10.1139/L06-014.
- Buonopane, S. G., Bian, G., Tun, T. H., and Schafer, B. W. (2015). Computationally efficient fastener-based models of cold-formed steel shear walls with wood sheathing.” *Journal of Constructional Steel Research*, 110, pp. 137–148, doi: 10.1016/j.jcsr.2015.03.008.
- CFSEI (2011). Technical Note G500-11 *Guidelines for inspecting cold-formed steel structural framing in low rise buildings*, Cold-Formed Steel Engineers Institute, Washington, DC.
- Chatterjee, A., Xiang, Y., Moen, C. D., Arwade, S. R., and Schafer, B. W. (2014). “Toward quantifying beneficial system effects in cold-formed steel wood-sheathed floor diaphragms,” *Proceedings of the 22nd International Specialty Conference on Cold-Formed Steel Structures*, Wei-Wen Yu Center for Cold-Formed Steel Structures, St. Louis, MO, pp. 903–918.
- Chen, Y. C. (2004). “Testing and performance of steel frame/wood panel shear walls,” master’s degree thesis, McGill University, Montreal, Canada.

- Comeau, G. (2008). "Inelastic performance of welded cold-formed steel strap braced walls," master's degree thesis, McGill University, Montreal, Canada.
- Comini, R., and Schafer, B. W. (2014). "Stability of energy-dissipating steel fuses in an innovative seismic system for cold-formed steel structures," *Proceedings of the Annual Stability Conference*, Structural Stability Research Council, Toronto, Canada.
- DaBreo, J. (2012). "Impact of gravity loads on the lateral performance of cold-formed steel frame/steel sheathed shear walls," master's degree thesis, McGill University, Montreal, Canada.
- Dubina, D. (2008). "Behavior and performance of cold-formed steel-framed houses under seismic action," *Journal of Constructional Steel Research*, 64 (7-8), pp. 896–913.
- Elhaji, N. (2005). *Cold-formed steel walls with fiberboard sheathing-shear wall testing: summary test report*, NAHB Research Center, Inc., Upper Marlboro, MD.
- El-Saloussy, K. (2010). "Additional cold-formed steel frame/steel sheathed shear walls design values for Canada," master's degree thesis, McGill University, Montreal, Canada.
- FEMA (1997). *NEHRP Guidelines for the seismic rehabilitation of buildings*, (FEMA 273), Federal Emergency Management Agency, Washington, DC.
- Feng, P., Chu, M., Ye, L., and Hou, J. (2010). "Experimental study on shear behavior of cold-formed thin-walled steel reinforced concrete shear walls," *Jianzhu Jiegou Xuebao/Journal of Building Structures*, 31 (11), pp. 83–91.
- Fiorino, L., Della Corte, G., and Landolfo, R. (2007). "Experimental tests on typical screw connections for cold-formed steel housing," *Engineering Structures*, 29 (8), pp. 1761–1773.
- Fiorino, L., Iuorio, O., and Landolfo, R. (2009). "Sheathed cold-formed steel housing: A seismic design procedure," *Thin-Walled Structures*, 47 (8-9), pp. 919–930.
- Fülöp, L. A., and Dubina, D. (2004). "Performance of wall-stud cold-formed shear panels under monotonic and cyclic loading—Part II: Numerical modeling and performance analysis," *Thin-Walled Structures*, 42 (2), pp. 339–349.
- Fülöp, L. A., and Dubina, D. (2006). "Design criteria for seam and sheeting-to-framing connections of cold-formed steel shear panels," *Journal of Structural Engineering*, 132 (4), pp. 582–590.
- Gad, E. F., Duffield, C. F., Hutchinson, G. L., Mansell, D. S., and Stark, G. (1999). "Lateral performance of cold-formed steel-framed domestic structures," *Engineering Structures*, 21 (1), pp. 83–95.
- Hikita, K. (2006). "Combined gravity and lateral loading of light gauge steel frame/wood panel shear walls," master's degree thesis, McGill University, Montreal, Canada.
- ICBO (1997). *Uniform building code*, International Conference of Building Officials, Whittier, CA.
- ICC (2012). *2012 International building code*. International Code Council, Washington, DC.
- ICC (2015). *2015 International building code*, International Code Council, Washington, DC.
- Iuorio, O., Fiorino, L., and Landolfo, R. (2014). "Testing CFS structures: The new school BFS in Naples," *Thin-Walled Structures*, 84, pp. 275–288.
- Kochkin, V. and Hill, R. (2006). *Cyclic testing of fiberboard shear walls with varying aspect ratios*, Report, NAHB Research Center, Inc., Upper Marlboro, MD.
- Krawinkler, H., Parisi, F., Ibarra, L., Ayoub, A., and Medina, R. (2000). *Development of a testing protocol for woodframe structures*, CUREE Publication No. W-02, Consortium of Universities for Research in Earthquake Engineering, Richmond, CA.

- Landolfo, R., Fiorino, L., and Della Corte, G. (2006). “Seismic behavior of sheathed cold-formed structures: Physical tests,” *Journal of Structural Engineering*, 132 (4), pp. 570–581.
- Leng, J. (2015). “Simulation of cold-formed steel structures,” Ph.D. dissertation, Johns Hopkins University, Baltimore, MD.
- Li, Y., Shen, S., Yao, X., Ma, R., and Liu, F. (2012). “Experimental investigation and design method research on low-rise cold-formed thin-walled steel framing buildings,” *Journal of Structural Engineering*, 139 (5), pp. 818–836, doi:10.1061/(ASCE)ST.1943-541X.0000720.
- Liu, P., Peterman, K. D., and Schafer, B. W. (2012). “Test report on cold-formed steel shear walls,” accessed 6/21/2016 at [www.ce.jhu.edu/cfsnees](http://www.ce.jhu.edu/cfsnees), Johns Hopkins University, Baltimore, MD.
- Lowes, L., and Altoontash, A. (2003). “Modeling reinforced-concrete beam-column joints subjected to cyclic loading,” *Journal of Structural Engineering*, 129 (12), pp. 1686–1697.
- Lu, S. (2015). “Influence of gypsum panels on the response of cold-formed steel framed shear walls,” master’s degree thesis, Montreal, Canada.
- Madsen, R. L., Nakata, N., and Schafer, B. W. (2011). *CFS-NEES Building structural design narrative, research report*, RR01, accessed 6/21/2016 at [www.ce.jhu.edu/cfsnees/publications.php](http://www.ce.jhu.edu/cfsnees/publications.php)
- McKenna, F., Fenves, G. L., Scott, M. H., and Jeremic, B. (2000). *Open system for earthquake engineering simulation (OpenSees)*. Pacific Earthquake Engineering Research Center, University of California, Berkeley, CA.
- Mirzaei, A., Sangree, R. H., Velchev, K., Comeau, G., Balh, N., Rogers, C. A., and Schafer, B. W. (2015). “Seismic capacity-based design of narrow strap-braced cold-formed steel shear walls,” *Journal of Constructional Steel Research*, (115), pp. 81–91.
- Moen, C. D., Tao, F., and Cole, R. (2016). “Monotonic and cyclic backbone response of single shear cold-formed steel screw-fastened connections,” *The International Colloquium on Stability and Ductility of Steel Structures*, Timisoara, Romania.
- Morello, D. (2009). “Seismic performance of multi-storey structures with cold-formed steel wood sheathed shear walls,” master’s degree thesis, McGill University, Montreal, Canada.
- Nikolaidou, V., Latreille, P., Lignos, D. G., and Rogers, C.A. (2016). *Characterization of CFS framed diaphragm behaviour*, Technical Report, section: 11.1.2, McGill University, Montreal, Canada.
- Ong-Tone, C. (2009). “Tests and evaluation of cold-formed steel frame/steel sheathed shear walls,” master’s degree thesis, McGill University, Montreal, Canada.
- Ozaki, F., Kawai, Y., Kanno, R., and Hanya, K. (2013). “Damage-control systems using replaceable energy-dissipating steel fuses for cold-formed steel structures: Seismic behavior by shake table tests,” *Journal of Structural Engineering*, 139, pp. 787–795.
- Padilla-Llano, D. A., Moen, C. D., and Eatherton, M. R. (2014). “Cyclic axial response and energy dissipation of cold-formed steel framing members,” *Thin-Walled Structures*, 78, pp. 95–107.
- Padilla-Llano, D. A., Eatherton, M. R., and Moen, C. D. (2016). “Cyclic flexural response and energy dissipation of cold-formed steel framing members,” *Thin-Walled Structures*, 98, Part B, pp. 518–532.
- Peterman, K. D. (2014). “Behavior of full-scale cold-formed steel buildings under seismic excitations,” Ph.D. dissertation, Johns Hopkins University, Baltimore, MD. CFS-NEES project publications and data were accessed 6/21/2016 at [www.ce.jhu.edu/cfsnees](http://www.ce.jhu.edu/cfsnees).
- Peterman, K. D., Nakata, N., and Schafer, B. W. (2014). “Hysteretic characterization of cold-formed steel stud-to-sheathing connections,” *Journal of Constructional Steel Research*, 101, pp. 254–264.

- Peterman, K. D., Stehman, M. J. J., Madsen, R. L., Buonopane, S. G., Nakata, N., and Schafer, B. W. (2016). "Experimental seismic response of a full-scale cold-formed steel framed building. I: System-level response," *Journal of Structural Engineering*, doi: 10.1061/(ASCE)ST.1943-541X.0001577.
- Rokas, D. (2006). "Testing and evaluation of light gauge steel frame/9.5 mm CSP wood panel shear walls," master's degree thesis, McGill University, Montreal, Canada.
- Schafer, B. W. (2008). "Review: The direct strength method of cold-formed steel member design," *Journal of Constructional Steel Research*, 64 (7), pp. 766–778.
- Schafer, B. W., Chen, H., Manley, B. E., and Larson, J. W. (2015). "Enabling cold-formed steel system design through new AISI standards," *Structures Congress 2015*, American Society of Civil Engineers, Reston, VA., pp. 995–1007.
- Schafer, B. W., Ayhan, D., Leng, J., Liu, P., Padilla-Llano, D., Peterman, K. D., Stehman, M., Buonopane, S. G., Eatherton, M., Madsen, R., Manley, B., Moen, C. D., Nakata, N., Rogers, C., and Yu, C. (2016). "Seismic response and engineering of cold-formed steel framed buildings," *Structures* (In press). doi: <http://dx.doi.org/10.1016/j.istruc.2016.05.009>.
- SDI (2011). SDI-QA/QC-2011. *Standard for quality control and quality assurance for installation of steel deck*, Steel Deck Institute, Glenshaw, PA.
- SEAO (1999). *Recommended lateral force requirements and commentary*, seventh edition, SEAO Seismology Committee, Structural Engineers Association of California, Sacramento, CA.
- SEAO (2008). *SEAO Blue book: Seismic design recommendations. September 2008 compilation*, Seismology Committee, Structural Engineers Association of California, Sacramento, CA.
- SEAO (2012). *IBC SEAO structural/seismic design manual, volume 2: Examples for light-frame, tilt-up and masonry buildings*, Structural Engineers Association of California, Sacramento, CA.
- Serrette, R., Enchalada, J., Hall, G., Matchen, B., Nyugen, H., and Williams, A. (1997a). *Additional shear wall values for light weight steel framing*, Report No. LGSRG-I-97, Santa Clara University, Santa Clara, CA.
- Serrette, R., Encalada, J., Juadines, M., and Nguyen, H. (1997b). "Static racking behavior of plywood, OSB, gypsum, and fiberboard walls with metal framing," *Journal of Structural Engineering*, 123 (8), pp. 1079–1086.
- SFA (2008). *Steel Framing Inspection Guide*, published jointly by Steel Framing Alliance, Washington, DC; Steel Stud Manufacturer's Association, Chicago, IL; and American Iron and Steel Institute, Washington, DC.
- Shamim, I. (2012). "Seismic design of lateral force-resisting cold-formed steel framed structures," Ph.D. dissertation, McGill University, Montreal, Canada.
- Shamim, I., Dabreo, J., and Rogers, C. A. (2013). "Dynamic testing of single- and double-story steel-sheathed cold-formed steel-framed shear walls," *Journal of Structural Engineering*, 139 (5), pp. 807–817.
- Shimizu, N., Kanno, R., Ikarashi, K., Sato, K., and Hanya, K. (2013). "Cyclic behavior of corrugated steel shear diaphragms with end failure," *Journal of Structural Engineering*, 139 (5), pp. 796–806.
- Uang, C-M. (1991). "Establishing  $R$  (or  $R_w$ ) and  $C_d$  factors for building seismic provisions," *Journal of Structural Engineering*, 117 (1), pp. 19-28.
- U.S. Army Corps of Engineers (2015). *Development of cold-formed steel seismic design recommendations*, (ERDC/CERL TR-15-16), U.S. Army Corps of Engineers, Engineer Research and Development Center, Vicksburg, MS.



- Velchev, K. (2008). “Inelastic performance of screw connected cold-formed steel strap braced walls,” master’s degree thesis, McGill University, Montreal, Canada.
- Winter, G. (1947). “Strength of thin steel compression flanges,” *Transactions of the American Society of Civil Engineers*, 112 (1), pp. 527–554, American Society of Civil Engineers, Reston, VA.
- Winter, G. (1972). “Thin-walled steel for modern structures: Thirty years of industry-sponsored research at Cornell,” *ENGINEERING*, Cornell Quarterly, 7 (1), pp. 2–12, doi: <http://hdl.handle.net/1813/2277>.
- Yenaga, N. and Yu, C. (2014). “Effective strip methods for the design of cold-formed steel framed shear wall with steel sheet sheathing,” *Journal of Structural Engineering*, 140 (4), doi: [http://dx.doi.org/10.1061/\(ASCE\)ST.1943-541X.0000870](http://dx.doi.org/10.1061/(ASCE)ST.1943-541X.0000870).
- Yu, C. (2010). “Shear resistance of cold-formed steel framed shear walls with 0.686 mm, 0.762 mm, and 0.838 mm steel sheet sheathing,” *Engineering Structures*, 32 (6) pp. 1522–1529.
- Yu, C., Vora, H., Dainard, T., Tucker, J., and Veetvkuri, P. (2007). *Steel sheeted options for cold-formed steel framed shear walls assemblies providing shear resistance*, Report No. UNT-G76234, University of North Texas, Denton, TX.
- Yu, C., and Chen, Y. (2009). *Steel sheeted options for cold-formed steel framed shear walls assemblies providing shear resistance—Phase 2*, Report No. UNT-G70752, University of North Texas, Denton, TX.
- Yu, W. W. and LaBoube, R. A. (2010). *Cold-formed steel design*, 4th edition, John Wiley & Sons, New York, NY.
- Zhao, Y. and Rogers, C. A. (2002). *Cyclic performance of cold-formed steel stud shear walls*, Progress Report No. 2, McGill University, Montreal, Canada.

# 13. Notations and Abbreviations

## Notations

$A_g$	gross cross-section area of a member	$\Omega$	specified safety factor as defined in AISI S400
$A_n$	net cross-section area of a member	$\Omega_o$	system overstrength factor as defined in ASCE 7
$C_a$	shear resistance adjustment factor as defined in AISI S400	$\Omega_E$	expected strength factor as defined in AISI S400
$C_d$	deflection amplification factor as defined in ASCE 7		
$F_u$	ultimate stress of steel		
$F_y$	yield point of steel		
$MCE_R$	maximum considered earthquake		
$M-\theta$	moment-rotation relationship that defines the backbone curve for seismic response		
$P-\Delta$	force-deformation relationship for a strap-braced wall		
$R$	seismic response modification factor as defined in ASCE 7		
$R_d$	ductility related force modification factor as defined in the National Building Code of Canada		
$R_o$	overstrength related force modification factor as defined in the National Building Code of Canada		
$R_s$	diaphragm forced reduction factor anticipated in ASCE 7-16		
$R_t$	expected ultimate stress adjustment factor as defined in AISI S400		
$R_y$	expected yield point adjustment factor as defined in AISI S400		
$V-\Delta_H$	shear deformation relationship for a shear wall		
$V_{be}$	elastic base shear		
$V_n$	nominal shear capacity as defined in AISI S400		
$V_o$	shear resistance of a building not explicitly accounted for in design		
$\Delta$	lateral displacement under seismic load		
$\phi$	resistance factor as defined in AISI S400		

## Abbreviations

AISC	American Institute of Steel Construction
AISI	American Iron and Steel Institute
ANSI	American National Standards Institute
APA	American Plywood Association
ASCE	American Society of Civil Engineers
ASTM	ASTM International (formerly American Society for Testing and Materials)
ATC	Applied Technology Council
AWS	American Welding Society
CFS	cold-formed steel
CFSEI	Cold-Formed Steel Engineers Institute
CUREE	Consortium of Universities for Research in Earthquake Engineering
DBE	design basis earthquake for elastic response
ELF	equivalent lateral force
EPP	elastic perfectly-plastic
FEMA	Federal Emergency Management Agency
IBC	International Building Code
ICC	International Code Council
LFRS	lateral force-resisting system
LRFD	load and resistance factor design
OSB	oriented strand board
SBMF	special-bolted moment frame(s)
SEAOC	Structural Engineers Association of California
SEI	Structural Engineering Institute
SFA	Steel Framing Alliance
SFRS	seismic force-resisting system
SPD	sequential phase displacement
WSP	wood structural panel(s)

## 14. Credits

Cover photo	Image courtesy of Don Allen.
Figure 2-1	Image courtesy of American Iron and Steel Institute, reprinted with permission.
Figure 4-3	Image courtesy of American Iron and Steel Institute, reprinted with permission.
Figure 4-5	Image courtesy of Simpson Strong-Tie Company, Inc., reprinted with permission.
Figure 4-6	Image courtesy of Colin Rogers, McGill University.
Figure 7-3	FEMA 237 © 1997, Federal Emergency Management Agency, Washington D.C.
Figure 10-1	Image courtesy of American Iron and Steel Institute, reprinted with permission.

Images not credited here were provided by the authors.